

SYSTEM ONE PUMP

FRAME S, FRAME A / LD17, VORTEX and FRAME M

Installation, Operation and Maintenance Manual

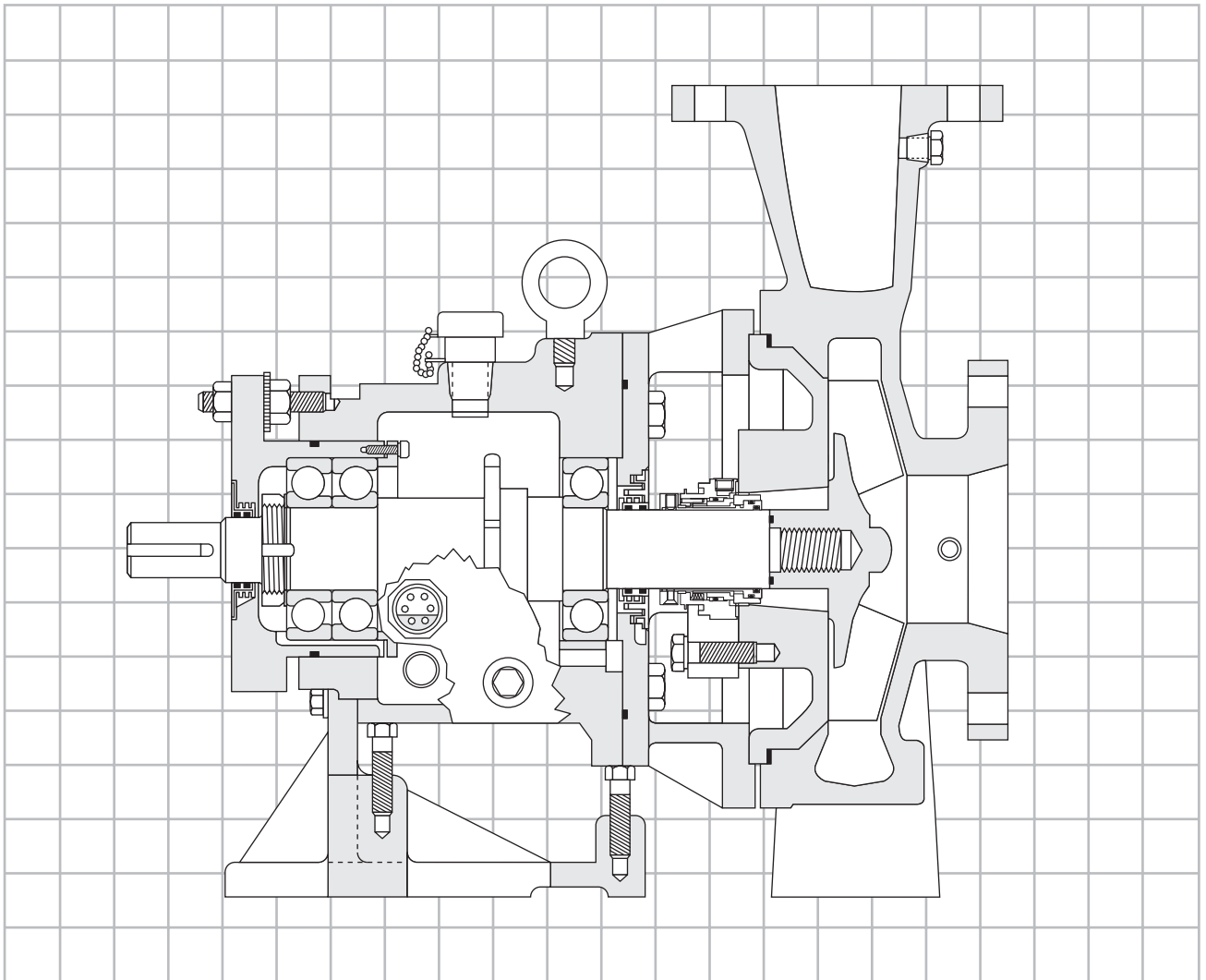

Blackmer
A DOVER COMPANY[®]

BLACKMER SYSTEM ONE PUMPS

Installation, Operation and Maintenance Manual Table of Contents

Pump Description And Safety Concerns	2	8.0 Pump Assembly Drawings And Parts Lists	28
1.0 Introduction	4	8.1 Frame S 6 in.	28
1.1 Receiving Shipment	4	8.2 Frame S 8 in.	29
1.2 Storage	4	8.3 Frame A	30
1.3 Warranty	4	8.4 LD17	31
1.4 Handling	4	8.5 Vortex, Frame A	32
2.0 Installation	5	8.6 Vortex, LD17	33
2.1 Motor Specifications	5	8.7 Frame M	34
2.2 Foundation	5	8.8A Outline and Base Plate Dimensions Frame S and M	35
2.3 Leveling	6	8.8B Outline and Base Plate Dimensions Frame A and LD17	36
2.4 Grouting	6	8.9 Outline and Pump Dimensions Frame S, A, LD17 and M	37
2.5 Coupling Alignment	6	9.0 Recommended Spare Parts Lists	38
2.6 Piping – Suction And Discharge	7	9.1 Frame S	38
2.7 Mechanical Seal	10	9.2 Frame A and Vortex	39
2.8 Lubrication	10	9.3 LD17 and Vortex	40
2.9 Temperature Control	11	9.4 Frame M	41
3.0 Operation	12	10.0 Pump Tolerances	42
3.1 Start-Up Inspection	12	11.0 Fastener Torque Values	43
3.2 Auxiliaries Start-Up	12	12.0 Ball Bearings	44
3.3 Priming	13	12.1 Handling, Removal And Inspection	44
3.4 Start-Up	13	12.2 Angular Contact Bearing Installation	44
3.5 Pump Performance	13	12.3 Double Row Bearing Installation	45
3.6 Shutdown	13	13.0 Pump Component Inspection	46
4.0 Maintenance	14	14.0 Troubleshooting	48
4.1 Disassembly Procedure	14	Notes	53
4.2 Assembly Procedure	16		
4.3 Impeller Total Clearance	19		
4.4 Impeller Operating Clearance	19		
5.0 Power End Conversions	21		
6.0 Mounting The Motor	22		
6.1 Foot Mounted Motor	22		
6.2 Coupling	22		
6.3 Motor Mounted On Motor Adapter	22		
7.0 Auxiliary Pipe Connections List	24		
7.1 Frame S	24		
7.2 Frame A and LD17	25		
7.3 Vortex Frame A and LD17	26		
7.4 Frame M	27		

Pump Description

Fill this in for your record purposes:

It will be critical to have this information for the accurate identification of spare parts which may be required later.

Pump Size: _____

Model: _____

Serial Number: _____

Date Received: _____

Impeller Diameter: _____

RPM: _____

Flow: _____

Head: _____

Application: _____

Material of Construction*: _____

Mechanical Seal Type: _____

*Nameplate includes material information for shaft (left) and wet end (right) in that order.

Safety Data Information



This is a SAFETY ALERT SYMBOL

When you see this symbol on the product, or in the manual, look for one of the following signal words and be alert to the potential for personal injury, death or major property damage.

▲DANGER

Warns of hazards that **WILL** cause serious personal injury, death or major property damage.

▲WARNING

Warns of hazards that **CAN** cause serious personal injury, death or major property damage.

▲CAUTION

Warns of hazards that **CAN** cause personal injury, or property damage.

NOTICE:

Indicates special instructions which are very important and must be followed.

NOTICE:

Blackmer System One Pumps **MUST** only be installed in systems which have been designed by qualified engineering personnel. The system **MUST** conform to all applicable local and national regulations and safety standards.

This manual is intended to assist in the installation, operation and maintenance of Blackmer System One Pumps and **MUST** be kept with the pump.

Pump service shall be performed by qualified technicians **ONLY**. Service shall conform to all applicable local and national regulations and safety standards.

Thoroughly review this manual, all instructions and hazard warnings **BEFORE** performing any work on the pump.

Maintain **ALL** system and pump operation and hazard warning decals, signs, placards, etc.

Maintenance Safety Data

⚠ WARNING



Hazardous or toxic fluids can cause serious injury.

- If pumping hazardous or toxic fluids, system must be flushed prior to performing service.
- Fluid must be handled and disposed of in accordance with local and national regulations.
- Contaminated parts must be cleaned properly following local and national regulations.
- Pump must be isolated by closing suction and discharge valves before working on the pump.
- Personal protective equipment must be worn if there is a potential for handling hazardous or toxic materials.

⚠ CAUTION



Hazardous pressure can cause personal injury or property damage.

- Failure to relieve system pressure prior to performing pump service or maintenance can cause personal injury or property damage
- Only use quality fasteners of proper size and material for application. If in doubt use only OEM supplied fasteners.
- Do not draw piping flanges to pump by force as this may cause dangerous strains within the pump case and misalignment between the pump and driver.
- Do not adjust or disassemble any pressure containing component or shaft seal prior to depressurizing the primary and auxiliary fluid systems. This will ensure that no hazardous or high pressure fluid is ejected that may cause personal injury or equipment damage.

⚠ WARNING



Hazardous machinery can cause serious personal injury.

- Lock out power to the driver before working on the pump. Failure to properly lock out motor could result in accidental start, causing personal injury.
- Wear proper safety equipment including gloves, glasses, respirators and shoes when working on the pump.
- Do not touch the pump for any reason while it is operating. Lockout or uncouple the driver prior to personal contact with the pump.
- When handling the pump or any pump components, take care to prevent personal injury on any possible sharp or odd-shaped surfaces.
- Be extremely careful to avoid the rotating components in the seal chamber area. Make all adjustments with the pump shut down and locked out.

⚠ DANGER



Explosive fluids will cause severe personal injury, death or major property damage.

- Do not apply heat to any component for removal or disassembly. Use of heat may cause an explosion due to trapped fluid within the pump.

⚠ CAUTION



Heavy assemblies can cause personal injury or property damage.

- Always use a lifting device capable of supporting the full weight of the pump components or assemblies

NOTICE:

- Do not use the pump for any other purpose than the liquid transfer application for which it is originally supplied.

Operational Safety Data

⚠ CAUTION



Hazardous pressure can cause personal injury or property damage.

- Do not operate the pump at higher than rated pressures or for any application other than that which it was designed for.
- Never operate below the minimum rated flow or with suction or discharge valves closed.
- Do not adjust or disassemble any pressure containing component or shaft seal prior to depressurizing the primary and auxiliary fluid systems. This will ensure that no hazardous or high pressure fluid is ejected that may cause personal injury or equipment damage.

⚠ WARNING



Hazardous fluids can cause fire, serious personal injury or property damage.

- Do not operate the pump without ensuring suction is primed with fluid.
- Do not operate the pump dry.
- Never operate the pump without liquid supplied to the mechanical seal. Running the mechanical seal dry, even for short periods, can cause seal damage and/or failure resulting in fluid release. Physical injury can occur if mechanical seal fails.

⚠ CAUTION



Extreme heat can cause injury or personal damage.

- Do not touch the pump while it is unisolated from hot or cold fluids, otherwise personal injury may result.

1.0 Introduction

1.1 Receiving Shipment

Immediately upon receipt of shipment, check the items received against those shown on the packing list. Check the bottom of the box for additional parts. Special attention should be given to all specific instruction tags that may be attached to the pump.

1.2 Storage

On completion of receiving and inspection, action must be taken to protect the equipment if it is not to be installed immediately. The unit should be kept dry and in its container until ready to install on its foundation. Please request the “Long Term Storage Specification” from the factory if the pump will not be used within several months or if it will be stored outdoors.

1.3 Warranty – Limitation Of Liability

Blackmer’s obligation under the warranty is expressly limited to replacing defective seals or parts of the seal and/or power end. In no event will Blackmer be liable for labor, lost production, damage or loss to persons or property, or consequential damages.

The warranty for shaft covers a shaft failure due to breakage or fretting caused by the factory installed mechanical seal. Any other type of surface damage (corrosion, erosion, damaged keyway or bending of the shaft) will not be covered.

Damage to shafts, lab seals or wet end components as a result of a bearing failure are not covered under the warranty program.

The warranty covers replacement of the failed bearing only. The other bearing or entire rotating element is not included.

This warranty excludes coverage for erosion and corrosion. Pumps and seals must be installed, operated and maintained within System One pump specifications and design parameters. An authorized Blackmer representative must approve applications including environmental controls.

For the extended warranty to be valid, a Pump Information Form for Serial Number Assignment must be supplied to Blackmer prior to shipment for all complete pump orders and power end orders.

1.4 Handling



WARNING:
Pumps and components are heavy. Failure to properly lift and support equipment could result in serious injury and damage to equipment.

A bare pump can be hoisted by the lifting eyebolt provided in the bearing frame. A pump on a baseplate can be hoisted by using a sling under the casing suction flange and under the motor end of the baseplate. If the base also contains a motor, lifting should be accomplished by placing slings under the motor and under the casing suction flange.

Do not lift the Pump, Motor, or Base Assembly by the use of the Eyebolts provided in the Pump and Motor

2.0 Installation

2.1 Motor specifications and requirements

Check that the motor power rating does not exceed the maximum power limitations of the pump as shown in the table below.

Maximum Power in HP (KW)					
RPM	Frame S	Frame A/LD17	Frame A/LD17	Frame M	Frame M 17inch
Shaft Material	316SS	316SS	17 – 4PH	316SS	17 – 4PH
3600	40 (30)	122 (91)	150 (112)	– –	– –
3000	33 (25)	100 (75)	125 (93)	– –	– –
1800	20 (15)	60 (45)	75 (56)	252 (188)	350 (261)
1500	16 (12)	50 (37)	63 (47)	210 (157)	290 (216)
1200	13 (10)	40 (30)	50 (37)	168 (125)	236 (176)
900	10 (7)	30 (22)	38 (28)	126 (94)	192 (143)

NOTE:

The specific gravity of the pump fluid must be considered when calculating HP (KW).

2.2 Foundation

The foundation is one of the most influential factors where overall reliability of the pump unit is concerned. The foundation must maintain alignment under all normal and abnormal conditions. The foundation must minimize vibration by being as heavy as possible and non-resonant. A generous factor of safety should be used when determining foundation thickness. The foundation length and width should extend at least 6 in. (152 mm) beyond the anchor bolts.

Certified pump elevation drawings can be furnished that include dimensions for locating anchor bolts, and general information needed for determining foundation size and thickness.

Anchor bolts must be positioned accurately and provided with sleeves. The sleeve bore diameter should be approximately twice the bolt diameter, but should provide not less than .5 in. (13 mm) clearance all around the bolt.

Pumps must be installed on an adequate foundation.

Proper "Footprint"

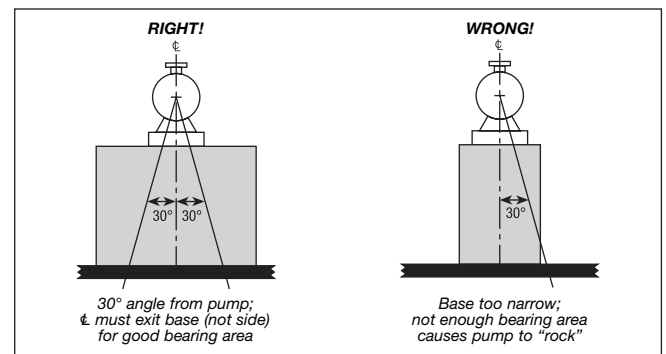

Proper Mass

Mass of foundation must be at least three (3) times mass of pump and motor.

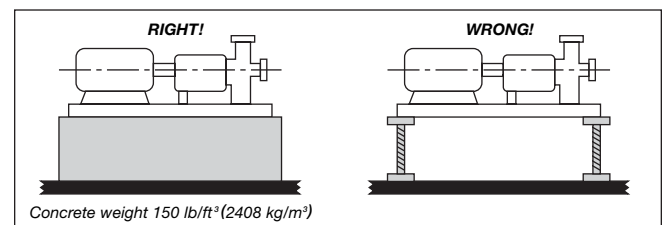

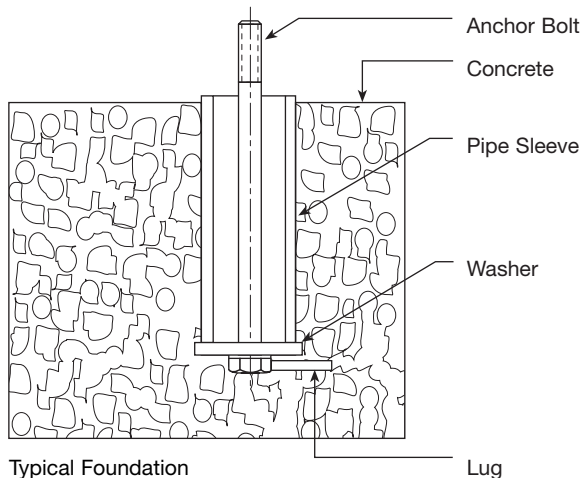

2.3 Leveling

Sufficient parallel machined bearing plates or chock blocks should be placed beneath the base along the sides and ends, to distribute the load evenly. It is essential that they are leveled before the base is placed in position. Obtain an accurate condition of level lengthwise and crosswise.

2.4 Grouting

The anchor bolts are used for hold down only. The grouting resists side thrust, end thrust and compensates for the irregularities between the foundation and the base, thus preventing the pump unit from shifting.

Use only a “high strength”, “non-shrinking”, “non-expanding”, grouting mixture.

Allow the grouting to set before tightening the anchor bolts. After tightening, check the coupling alignment to make sure it has not changed. Realign as required per the instructions in section 2.5.

NOTICE:

Do not connect piping to the pump until the grouting is sufficiently cured.

2.5 Coupling Alignment



WARNING:

Be sure to lock-out electrical power to the driver before performing alignment. Failure to lock-out power could result in serious injury.

NOTICE:

Check the driver direction of rotation BEFORE coupling it to the pump. The direction of pump rotation is indicated on the front surface of the casing. Improper direction of rotation will damage the pump.

Good service life of the pump and driver depends upon good alignment through the flexible coupling. If the electric motor was mounted at the factory, the pump and motor were in alignment when shipped.

Coupling Information:

- Pump and motor coupling should be the flexible type.
- Select a spacer coupling for pumps that do not use a motor adapter.
- Shaft gaps are as follows for non C frame pumps:
 - Frame S and Frame A 3.5 in. (89 mm)
 - Frame M 5.0 – 7.0 in. (127 – 178 mm)
- Select a non-spacer or semi-spacer type for use with a motor adapter, depending on shaft gap.
- If a motor adapter is used, check to see if the selected coupling will fit inside the adapter.
- There should be at least 0.12 in. (3 mm) gap between the pump and motor shafts on pumps with motor adapters.
- When aligning the shafts, the coupling should be disconnected and the coupling halves brought into alignment.

Alignment Checks:

- **Alignment is not required on a pump unit incorporating a motor adapter between the pump and the motor.**
- Cold alignment should be checked before and after baseplate is grouted.
- Piping should be connected to the pump prior to cold alignment.
- Final or hot alignment is to be done after the pump and driver have operated for a sufficient length of time to attain operating temperature.
- Periodic checks of alignment should be made to ensure smooth, continuous operation.
- Any changes to process conditions warrant an alignment check.



WARNING:
Once alignment is completed, the coupling guard must be installed to prevent injury. Never operate pump without coupling guard properly installed.

NOTICE:

The alignment between the driver and pump should be inspected after installation to ensure that transportation or other handling has not caused misalignment of the unit.

- Alignment must not be attempted until the base is in position and the mounting and flange bolts have been tightened. Alignment should be performed after the pump and driver are at operating temperature.

Alignment Method:

- There are numerous devices and methods for accomplishing proper coupling alignment. Specific alignment method is the customer's choice. If information is required for the double dial indicator method, the Blackmer factory can provide details. Also, information is available in the Hydraulic Institute Standards. Please be aware that both angular and parallel misalignments must be corrected.

Alignment Criteria:

- The unit without motor adapter is in complete alignment when offset and angular Total Indicated Runout (TIR) measure less than .005 in. (.13 mm). Offset alignment is measured on the rim of the coupling and angular alignment is measured on the face of the coupling. If either reading exceeds these values, corrections must be made.

2.6 Piping

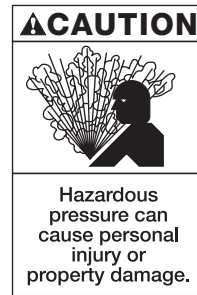

WARNING:
Never draw piping to the pump flanges by force. This may cause dangerous strains within the pump case and misalignment between the pump and driver. The result could be serious injury and damage to the equipment.

Proper piping details are provided by the Hydraulics Institute Standards.

Piping Strain

The suction and discharge pipe flanges must be aligned concentric and parallel to the pump flanges. The piping must be supported independently near the pump, and all flanges must match so that no strain will be transmitted to the pump after the nuts and bolts have been securely fastened. When tightening the nuts and bolts, always tighten bolts 180° opposite from each other in an alternating pattern to achieve even gasket compression.

The piping system should be designed with sufficient inherent flexibility to withstand thermal expansion without creating excessive forces at the flanges. The piping must also be arranged and supported so that no excessive stress can be transmitted to the pump, either due to the weight of the pipe and fluid, or to its expansion and contraction.

NOTICE:

Do not draw the piping into the pump by force as this will cause strain on the pump resulting in reduced seal and bearing life.

Excessive strain on a pump may be the result of:

1. Thermal expansion and contraction of the piping. This indicates improper piping design. Expansion joints or loops may have to be installed.
2. Improper pipe support. Frequent problems arise from indiscriminate use of rod hangers (instead of spring hangers), anchors or restraints used during the pipe installation.
3. Misalignment of the pipe flanges to the pump suction and discharge flanges.

Suction Piping

Rules of Thumb:

- Generally the suction piping is no more than one size larger than the pump nozzle. Suction lines should never be smaller than the pump suction nozzle.
- To prevent cavitation in the pump, suction line velocities should not exceed 10ft./sec.
- Typical fluid velocity guidelines are 4 to 6 ft./sec. for suction and 6 to 10 ft./sec. for discharge.
- The pressure drop across permanent suction strainers must be considered when determining suction pressure at pump inlet.
- Install valve stems and tee branches perpendicular to, not parallel to, the pipe centerline.

NPSH:

The pump must have enough positive suction head to prevent cavitation. The NPSH available (NPSHa) must always be greater than the NPSH required (NPSHr). Refer to the pump performance curve for NPSHr information.

For submerged suction, the inlet must be located deep enough to prevent vortexing. If necessary, provide vortex breakers in the suction vessel to prevent vortex formation.

The suction piping must be free of air pockets. Use an eccentric reducer if joining suction piping of different sizes to reduce the chance of an air pocket forming at the junction. Reference recommended configuration below.

NOTICE:

Never control the pump flow by throttling a valve in the suction line. The function of the suction valve is to isolate the pump from the system during maintenance.

It is recommended to have a straight length of suction piping, equal to at least five (5) times the diameter of the pipe, directly in front of the pump suction flange. Never place an elbow directly in front of the suction flange.

Elbows in suction piping should be of the long radius type.

Separate suction lines are recommended when more than one pump is operating from the same source of supply.

Suction strainers must have a total free area of at least 3x the suction pipe area.

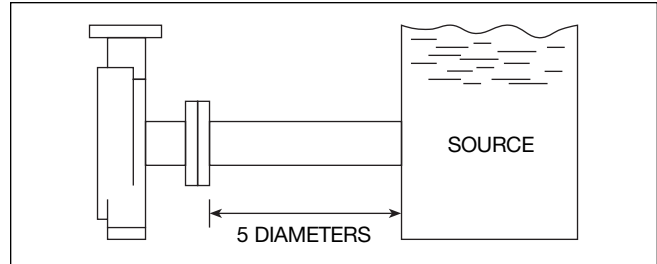

Preferred piping configuration with a minimum of 5 diameters of straight pipe between the source and the pump suction.

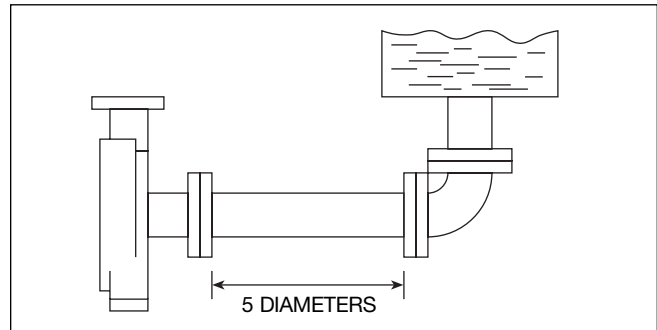

Elevated source. Preferred piping to be in one plane, again with a minimum of 5 diameters of straight pipe between the elbow and the pump suction.

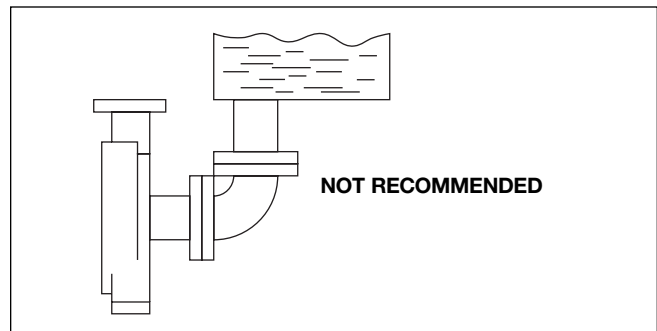

If the elbow bolts directly to the pump's suction, problems may occur. The liquid tends to follow the longer radius creating a void or even reverse flow along the shorter radius, thus starving part of the impeller.

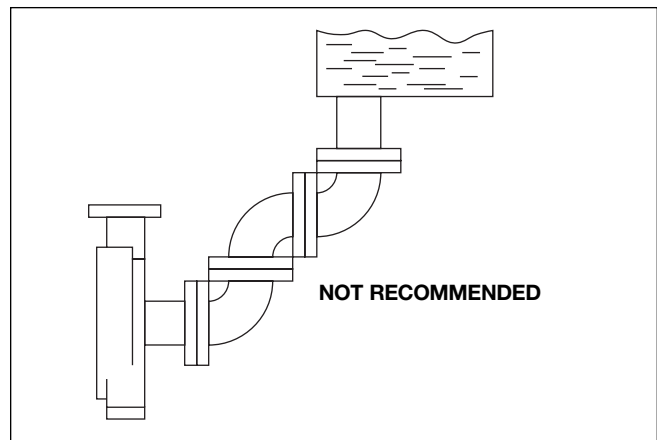

Avoid situations where there are many elbows in many planes.

Reducers

Rules of Thumb:

- Typically suction piping is no more than one diameter larger than pump suction nozzle.

Orientation:

- Suction above centerline:
Eccentric – Flat side on bottom,
or concentric.

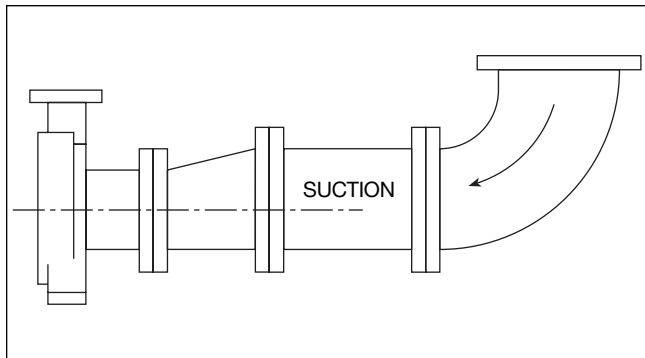

- Suction below centerline:
Eccentric – Flat side on top,
concentric not recommended.

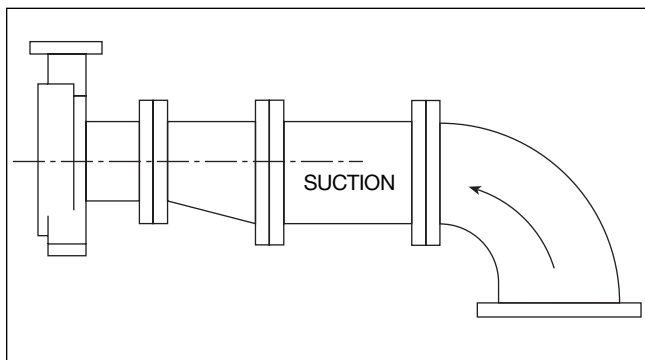

Piping Installation

Rules of Thumb:

- Piping runs should be as short as possible to minimize friction losses.
- Concentricity of the flanges should be such that the bolts can be inserted into the flange holes with finger pressure only. No spud wrenches or come-a-longs are to be used to align the flange holes.
- Piping should be anchored, restrained and supported independent of pump, near the suction and discharge to prevent excessive nozzle loads.
- Parallelism of the flange gasket surfaces are to be limited to 0.002 in./in. of normal pipe size, with a maximum of 0.03 in.

Example 4 in. pipe:

$$4 \times 0.002 \text{ in.} = 0.008 \text{ in. max.}$$

- Pipe sizes under 3.0 in. are flexible enough to allow a 0.008 in. maximum out-of-parallelism without causing shaft alignment problems.
- The last 20 ft. of piping to the pump suction and discharge flanges should be connected and tightened only after the pump is grouted and aligned.
- Dial indicators should be installed from the driver to the pump to monitor movement when the piping is bolted up. The maximum acceptable movement is 0.002 in.
- Tighten flange bolt to 2/3 torque valve using crisscross pattern for first pass then to final bolt torque in a circular pattern.

Discharge Piping

A check valve and an isolation valve must be installed in the discharge line. Locate the check valve between the isolation valve and the pump. The check valve protects the pump from running backwards when it is shut down. The isolation valve is used when starting the pump to prevent the pump from running out on the pump curve by throttling while the system is being filled. The isolation valve also isolates the system when the pump is pulled for maintenance.

Reducers should be located between the check valve and the pump to prevent excessive flow restriction that may be caused by an undersized valve.

If prolonged periods of near shutoff operation are experienced due to system demand, it may be necessary to install a recirculation line, off the discharge line, which returns to the supply reservoir below the liquid level. A valve or orifice should be installed in the bypass line to regulate flow. In some cases, an automatic valve is needed to regulate flow or to prevent excessive stops and starts, especially when using large motors.

The pump should be protected from surges and water hammer from quick acting valves in the system.

For auxiliary pipe connections, see section 7.0.

2.7 Mechanical Seal

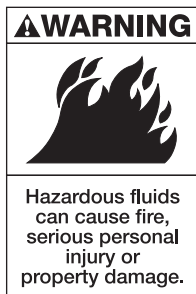

WARNING:
Never operate the pump without liquid supplied to the mechanical seal. Running the mechanical seal dry, even for short periods, can cause seal damage and/or failure. Physical injury can occur if mechanical seal fails.

The mechanical seal is flushed and cooled by either the pumped fluid or an external source. If the mechanical seal is flushed from an external source, it is required that the media be clean, solid free, and compatible to the pumped fluid.

Quench, vent, and/or drain ports are available on some seals. Ensure proper connections are made when the application requires it. Always follow all instructions provided with the seal

Prior to pump operation:

1. Be sure all set screws are tightened to the shaft.
2. Check that all centering clips are removed.
3. Ensure that all required mechanical seal auxiliary systems are installed and properly connected.

Seal life is dependent on a number of factors including cleanliness of process, operating conditions, etc. As such it is difficult to predict actual seal life for a given application.

2.8 Lubrication

Bearing Oil Lube

The pump bearing frame must be filled with a high quality, anti-foaming turbine oil containing rust and oxidation inhibitors.

Bearing temperatures should not exceed 180° F (82° C) thus an ISO VG 68 oil should be used.

Some recommended oils are:

- Texaco Regal R + O NO. 68
- Mobil DTE Heavy Medium
- Shell Turbo NO. T68
- Shell Omala 68
- Royal Purple Synfilm ISO VG 68 (synthetic)

The oil should be changed every 12 months with more frequent changes under severe environmental conditions, such as dust, moisture and corrosive atmospheres.

Lubricating Oil Properties:

ISO GRADEVG 68
 Approximate SSU at 100°F (40°C)300
 Kinematic Viscosity at 100°F (40°C) (cSt) . .68

Oil Level

For good performance, the oil level in the bearing frame should be one-half (1/2) of the way up the oil sight glass with the unit not operating.

If there is a slight loss of oil through the lab seals:

1. Lower the oil level to approximately 1/3 sight glass height.
2. Check that the pump bearing frame is level.
3. Check that oil return groove in cartridge is at 6 o'clock ("blackmer" should be across the top at 12 o'clock).
4. Check that radial lab seal stator drain is at 6 o'clock (Frame A and M only).

Bearing Frame Oil Volumes:

Frame S .22 quarts (208 ml)
 Frame A .74 - .79 quarts (700 - 748 ml)
 Frame M 1.26 - 1.34 quarts (1192 - 1268 ml)

Bearing Grease Lube

Use a premium quality lithium grease, having an NLGI 2 or 3 consistency and a base oil viscosity of 68 centistokes minimum at 40°C. When reassembling a pump, the bearings are best pregreased after assembly onto the shaft.

The bearings should be packed full with grease and the bearing housing adjacent to the bearings packed one third to one half full.

NOTICE:

Never mix greases of different consistencies.

Please note that vertical pumps are all grease lubed and that bearings are greased at the factory, thus no additional grease at installation is required.

Some recommended greases are:

- Chesterton #615
- SKF LGMT2/LGMT3

Regreasing Intervals:

For back to back angular contact, single and double row bearings, add several shots of grease from a grease gun at following intervals.

1. At 1180 RPM,
add grease every 5000 hours.
2. At 1750 RPM,
add grease every 4000 hours.
3. At 3550 RPM,
add grease every 1250 hours.

At bearing temperatures above 150°F (66°C), the bearings require regreasing more often. Greasing intervals should be halved for every 27°F (15°C) increase. Maximum grease temperature should not exceed 185°F (85°C). Completely replace the grease at every third regreasing interval, or once a year minimum.

NOTICE:

Over greasing is the most common cause of bearing overheating and will contribute to premature bearing failure.

Coupling Lubrication

The pump coupling may or may not require lubrication. For information on lubrication, refer to the coupling manufacturer's instructions.

2.9 Temperature Control**NOTICE:**

Normal operating oil temperature should be below 160°F (71°C) and should never exceed 180°F (82°C).

Bearing Frame

Water cooling of the bearing frame is accomplished with the optional cooling coil. The cooling coil is required only when the pumped media temperature exceeds 400°F (204°C) at 1800 rpm or 300°F (149°C) at 3600 rpm. Under these conditions, ambient temperature water at 1 - 3 gallons per minute (.23 to .68 m³/hr) will be required for proper cooling of the oil. Higher flows may be required to keep the oil temperature below the maximum recommended.

The cooling water must be turned on before the hot process fluid is allowed to enter the pump.

The optional System One Oil Temperature Monitor is recommended for all applications, especially for high temperature.

Seal Chamber

A water jacketed seal chamber is available for Frame S, A, and M pumps. The requirements for the jacket are based on the type of mechanical seal and selection of elastomers.

Normally, a jacket should be considered for any application over 350°F (177°C). Please consult the factory for specific recommendations.

When a jacket is installed, ambient temperature water at 2 - 3 gallons per minute (.45 to .68 m³/hr) will be required for proper cooling of the seal chamber.

Mechanical Seal

The seals may be cooled/heated from an external source or by passing pump discharge fluid through a heat exchanger and then into the seal flush connection.

A double seal may use cooled/heated barrier fluid from an external source or convection system. Always follow seal operating instructions as required by the instruction booklet provided with the seal.

3.0 Operation

3.1 Start-Up Inspection

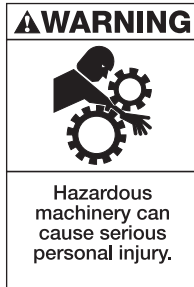

WARNING:
Lock-out driver to prevent accidental start-up and physical injury.

1. Check Installation.
Make certain the entire pump is properly aligned, and all auxiliary systems are connected and ready for implementation.
2. Check Direction Of Rotation.

NOTICE:
Improper direction of pump rotation will damage the pump.

When checking for proper direction of rotation, the coupling must be completely disconnected from the pump and driver. Run the driver independently to check for proper direction of rotation. Direction of the pump rotation is clockwise when viewed from the coupling end and is indicated by an arrow on the front of the casing.

Once direction of rotation is confirmed, reconnect coupling and confirm alignment.

3. Check Impeller Clearance.

NOTICE:
Pump units have impeller clearance pre-set prior to shipment from factory.

NOTICE:
Setting impeller clearance is important for maintaining maximum pump efficiency. For high temperature applications, compensation for additional thermal growth must be made.

Set impeller clearance.

- a. Unfasten the mechanical seal from the shaft when making adjustments.
- b. Check total clearance and make certain it conforms to the instructions given. (section 4.3).
- c. Set the proper operating clearance on the suction side of impeller (except Vortex type which is set off the back cover). (section 4.4).

- (1) If the pumpage temperature, exceeds 100°F (38°C) increase the clearance on the suction side of the impeller per section 4.4 of this manual.

4. Check Rotating Element.
Turn the shaft by hand several times to ascertain a free rotating element. There will be a degree of resistance due to the bearings and the mechanical seal. If any rubbing noise occurs, do not attempt to operate the pump. Re-adjust the impeller clearance as outlined in section 4.3 and 4.4 and reset the mechanical seal per its instructions.
5. Check Lubrication.
Check the pump, motor and coupling to make certain they are properly lubricated. See section 2.8 for pump lubrication information.
6. Check Radial Bearing Labyrinth Seal (Frames A and LD17 only).
If the frame adapter is rotated, relocate the stator portion of the labyrinth so that the oil drain groove is located at the 6 o'clock position.

3.2 Auxiliaries Startup

Prior to priming and starting the pump, auxiliary components on the unit must be turned on where applicable. The pump motor must not be started until all the auxiliary systems are in full operation.

Bearing Frame Cooling

If applicable, turn on the water to the cooling coil in the bottom of the oil sump. For proper flow, see section 2.9.

Mechanical Seal

If applicable, turn on the flush, quench or forced barrier fluid to the mechanical seal. Adjust flow and pressure as recommended by the installation instructions provided with the sealing device. If environmental controls include a heat exchanger, turn on the heating/cooling fluid.

Seal Chamber Jacket

If applicable, turn on the water to the cooling jacket mounted on the seal chamber. For proper flow, see section 2.9.

3.3 Priming

The pump is now ready to be primed.

1. Close the pump discharge valve.
2. Open the pump suction valve.

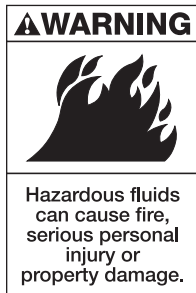

WARNING:
Never operate the pump dry. It is important that the pump never be subjected to thermal shock. The liquid must be allowed to enter the pump casing slowly. A centrifugal pump should never be started until all parts have been gradually brought to the ultimate intended pump temperature.

3. After priming ensure that all vent and/or ejector connections are closed.

3.4 Startup

NOTICE:
Prior to startup, ensure the shaft turns freely by hand! (clockwise when facing the coupling end)

Fully open the suction valve. Start the pump with the discharge valve approximately 20% open, then open gradually until design flow point is reached. The discharge valve should be adjusted to achieve proper process flow with the pump operating as close to the BEP as possible. Make certain the suction line is not throttled nor restricted in any way during operation.

3.5 Pump Performance

After the pump is running, check to see that it is running at, or close to, the operating point on the pump performance curve. If the pump is delivering too great a volume, or overloading the motor, throttle the discharge valve. It may be necessary to add a restriction orifice at the pump discharge to control the pump capacity.

Check and monitor all the flows and pressures to the auxiliary components. Adjust the flows and pressures accordingly.

Check the mechanical seal for leakage. Check all connections for possible leaks and tighten where necessary.

After the pump has run for about one hour and is at full operating temperature, shut it down, and turn (in the direction of the

rotation arrow) the shaft by hand to determine that the rotating element is not binding and the impeller is not rubbing. Shaft alignment should be checked. See section 2.5 for coupling alignment.



WARNING:
Never operate the pump below minimum rated flow and/or with the discharge valve closed. These operating conditions could cause extreme temperature rise in the pump and an explosive hazard. Also, premature failure can result due to high radial loads and vibration on the pump shaft.

3.6 Shutdown

When shutting down the pump, proceed as follows:

1. Turn off the driver and de-energize power. Be sure motor is locked out before attempting to work on the pump.

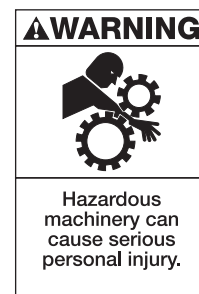

WARNING:
Lock-out driver to prevent accidental start-up and physical injury.

2. Close the discharge valve.
3. Close the suction valve.
4. Drain the pump casing.
5. Turn off all auxiliary components in the reverse sequence from startup.
6. In cold weather, the entire pump, including all auxiliary components, should be completely drained to prevent damage from freezing.

Tagging valves should be standard practice by user.

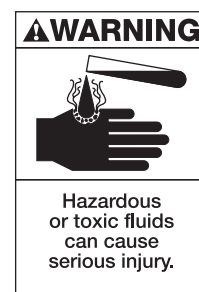

WARNING:
When handling hazardous and/or toxic fluids, use personal protection equipment to avoid personal injury. Pumpage must be handled and disposed of in accordance with applicable environmental regulations.

4.0 Maintenance

4.1 Disassembly Procedure

CAUTION



Heavy assemblies can cause personal injury or property damage.

WARNING:
Always use a lifting device capable of supporting the full weight of the pump components or assemblies

WARNING



Hazardous or toxic fluids can cause serious injury.

WARNING:
Personal protective equipment must be worn if there is a potential for handling hazardous or toxic materials. Fluid must be handled and disposed of in accordance with local and national regulations. Pump must be isolated by closing suction and discharge valves before working on the pump.

WARNING



Hazardous machinery can cause serious personal injury.

WARNING:
Lock-out power to the driver before working on the pump. Failure to properly lock-out driver could result in accidental start, causing personal injury.

CAUTION



Hazardous pressure can cause personal injury or property damage.

WARNING:
Do not adjust or disassemble any pressure containing component or shaft seal prior to depressurizing the primary and auxiliary fluid systems. This will ensure that no hazardous or high pressure fluid is ejected that may cause personal injury or equipment damage.

The System One Pump design incorporates the back pullout feature. This permits removal of the entire power end assembly, including the seal, back cover and impeller, without disturbing the discharge piping, suction piping or motor. The power end with C-frame or D-flange motor adapter

can also be removed as a unit if the motor is wired with flexible conduit.

Remove The Power End Assembly

See the appropriate pump assembly drawing in section 8.0.

1. Lockout driver and tag it.
2. If pump has a C-frame adapter and power is rigid piped, disconnect the power connection at driver.
3. Remove the coupling guard.
4. Disconnect the coupling between the pump and the driver shafts by removing the spacer piece between the hubs. If the pump has a motor adapter and the driver is suspended and wired with flexible conduit, the coupling will not have to be removed.
5. Drain the entire system and be sure there is no liquid left in the pump casing.
6. Disconnect inlet and outlet lines to the mechanical seal, if applicable.
7. Remove the screws or nuts securing the casing (1) as follows:
 - a. **Frame S**
6 in. pumps:
 Remove 4 nuts from studs that fasten the bearing frame ring (19) to casing (1).
8 in. pumps:
 Remove 8 nuts from studs that fasten the adapter plate (432) to the casing (1).
 - b. **Frame A and LD17**
8 in. (200 mm), 10 in. (250 mm) pumps:
 Remove nuts securing frame adapter (71) to casing (1).
13 in. (330 mm) pumps:
 Remove 12 fasteners securing back cover (11) to casing (1).
 - c. **Frame M:**
 Remove nuts that fasten the frame adapter (71) to the casing (1).

DANGER



Explosive fluids will cause severe personal injury, death or major property damage.

WARNING:
Never use heat to remove parts. Use of heat may cause an explosion due to trapped fluid resulting in physical injury and property damage.

8. Unfasten the holddown bolts between the bearing frame foot (400) and the pump baseplate, also 8 in. adapter plate motor feet and motor adapter if applicable. Be sure to mark any shims so that they can be replaced appropriately during reassembly.
9. The complete power end assembly can now be removed from the pump casing (1). Jackbolts are located on the frame adapter ring to help remove the backcover from the frame adapter.
10. The vortex pump has a separate suction cover (9) that can be replaced if worn.

Remove the Impeller, Back Cover and Seal

1. Remove the impeller (2) and o-ring (38) from the shaft (6). The impeller has a right hand thread. Some impellers have a hex nut cast into the face. The coupling end of the shaft can be held firm with the System One shaft wrench. Do not put a pipe wrench directly on the shaft (a coupling hub works well if necessary). The System One shaft wrench is recommended for this operation as it provides proper leverage for easy impeller removal:
 - a. Insert the shaft wrench onto the coupling end of the shaft.
 - b. Grip the impeller and rotate clockwise to lift the wrench off the work surface.
 - c. Quickly turn the impeller counter-clockwise (facing suction end) impacting the wrench handle on the work bench until the impeller loosens.

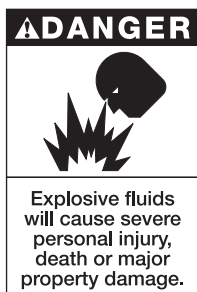

WARNING:
Never apply heat to remove an impeller as trapped fluid could cause an explosion resulting in physical injury and property damage.



WARNING:
Wear heavy work gloves when handling impellers as sharp edges may cause physical injury.

2. Install the mechanical seal centering clips if available. Remove the seal gland stud nuts. Remove backcover/frame adapter nuts quantity 2 except for 13 in. Frame A pumps which have quantity 8, then remove the back cover (11) assembly from the frame adapter (71). Loosen the set screws on the mechanical seal to free it from the shaft (6), then remove the seal.
3. Drain the oil from the bearing frame (19) by removing the plug (414) below the oil level sight glass (143). If the optional System One temperature monitor is installed, it is removed to drain oil.
4. If the power end is to be completely disassembled, remove the motor adapter at this time.
5. Remove the frame adapter/bearing frame screws (quantity 4 for Frame A, quantity 8 for Frame M) and remove the frame adapter (71) from the bearing frame (19) (not applicable to Frame S).
6. Clean and lubricate the shaft surface to facilitate removal of the labyrinth seal. In doing so, the rotor portion of the radial labyrinth seal (89E) with two flouorocarbon (FKM) o-rings (89F) will slide off the shaft (6).
7. Press out the stator (89D) portion of the radial labyrinth seal if replacement is required (not applicable to Frame S as the stator is integral to the bearing frame). For Frame M pumps, the radial labyrinth rotary seal (89E) will not be removed with the frame adapter (71) as it is part of the radial labyrinth seal acting as a radial bearing cover.

Remove and Disassemble the Rotating Element

1. The rotating element assembly can now be removed from the bearing frame (19) (after removal of C-frame or D-flange motor adapter if supplied). Remove the cartridge lock nuts (404), quantity 3 for Frame S and A, quantity 4 for Frame M. Slide the rotating element out from the back end of the bearing frame (19).
2. The micrometer nuts (66) can be used to help disengage the cartridge o-ring (405) from the bearing frame (19).
3. The rotating element assembly can now be disassembled. Remove the pump half of the coupling from the shaft (6) if this has not already been done.
4. Remove the bearing retainer screws and the bearing retainer cover (35) from the cartridge (33).
5. Clean and lubricate the shaft surface at the motor end to facilitate removal of the labyrinth seal. Remove the cartridge (33) with o-ring (405) from the rotating element. In doing so, the rotor portion of the thrust labyrinth seal (89B) with two o-rings (89C), will slide off the shaft.
6. Press out the stator portion of the labyrinth seal (89A) from the cartridge if replacement is necessary. The Frame S, Frame A and Frame M have stators as part of the thrust cartridge (the Frame A has a separate thrust labyrinth seal stator in pre-2000 models).
7. Bend out the locking tab from the locking slot in the lock nut (22). Remove the thrust bearing lock nut (22) and lock washer (69). The threads on the shaft are right hand.

For detailed instructions on handling and removing bearings, see section 12.0

8. Press the thrust bearings (18) from the shaft (6) using an arbor press. A fixture is necessary (split steel plate with a bored hole of the same diameter as the maximum shaft diameter) to hold the shaft in the arbor press by the inner race of the bearing and to allow the press arbor to contact the end of the shaft. Care is necessary so that the shaft is not scratched or bent. Shaft must be perfectly aligned under the arbor. Do not use a hammer or other tools that may damage the shaft.

NOTICE:

Always press on the inner race of the bearings when removing from a shaft.

9. Press the radial bearing (16) from the shaft (6) in the same manner.
10. Loosen the flinger set screw and remove the flinger (62) along with the bearing retainer cover (35) from the shaft (6). Frame S pumps do not have a flinger.

4.2 Assembly Procedure

- See Fastener Torque Chart section 12.0 at the end of the manual

Assemble Rotating Element

1. Clean all parts thoroughly, especially gasket surfaces, fits, and the inside of the oil sump.
 2. Replace all o-rings, gaskets, thrust bearings, the radial bearing, and mechanical seal wear parts.
 3. Inspect all remaining parts and determine if they should be reused, repaired or replaced. Use good judgement for a successfully reconditioned pump.
- See Pump Component Inspection section 13.0 and Pump Tolerances 10.0 at the end of the manual.
4. Slide the flinger (62) on the shaft (6). The Frame S has no flinger.
 5. Mount the bearing retainer cover (35) loosely on the shaft (6) with the smaller diameter ring facing toward the coupling end.
- For detailed instructions on Bearing Installation see section 11.0
6. Heat the thrust bearing(s) (18) in hot oil, or with an induction heater, to a temperature of 240°F (116°C). Using clean, insulated gloves, mount the hot thrust bearings back-to-back (letters to letters) on the coupling end of the shaft (6). For Frame A and M, be sure the bearings are tight against each other. The standard Frame S thrust bearing is one piece only and can be mounted in either direction (except for optional angular contact bearings). Make sure bearings are seated against shaft shoulder.

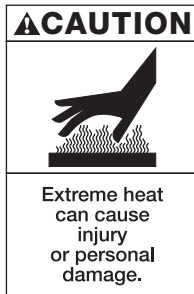

WARNING:
Wear insulated gloves when using a bearing heater. Hot bearings can cause physical injury.

Maximum Allowable Tightening Torque For Bearing Locknuts

Bearing Designation	Locknut Designation	Maximum Allowable Tightening Torque
5308	N-08	35 ft-lbf (47 N-m)
7310 BEA	N-10	70 ft-lbf (95 N-m)
7314 BEA	N-14	170 ft-lbf (230 N-m)

7. Install the lockwasher (69) on the shaft with the tab in the keyway. Fasten securely with the lock nut (22) and tighten with a spanner wrench per the corresponding torque shown in the chart above. When cooled, tighten again to make certain the thrust bearing inner race is against the shaft shoulder and the outer races do not turn against each other. If the bearing has to be reset, remove the locknut and use an arbor press with a sleeve to seat the inner race of the bearing eliminating any clearance. Finally, turn down the appropriate tab on the lock washer into the matching slot on the lock nut.
8. Heat the radial bearing (16) in hot oil, or with an induction heater, to a temperature of approximately 240°F (116°C). Using clean insulated gloves, mount the hot radial bearing on the impeller end of the shaft (6) and bottom against shaft shoulder. Allow the bearing to cool on the shaft in the vertical position so that the bearing will stay seated against the shaft shoulder while it shrinks to the shaft.
9. Press in the new labyrinth seal stator (89) if replacement is necessary. Press in until the face of the stator is flush with the machined tooth in the housing. Make certain that the oil return groove aligns itself with the oil return slot in the I.D. of the cartridge. The side with the smallest I.D. should face inside the cartridge.
10. Mount the new o-ring (405) in the groove on the O.D. of the cartridge (33).
11. Mount the cartridge (33) over the thrust bearings (18) until the outer race is seated against the shoulder inside the cartridge. Slight heating of the cartridge and lightly oiling the OD of the bearing will ease this assembly.
12. Fasten the bearing retainer cover (35) to the cartridge (33) and evenly torque in an alternating pattern the quantity 8 socket head cap screws to the value shown in the bolt torque chart. See section 12.0.
13. Mount the micrometer nuts (66) on the cartridge studs (403) at the coupling end of the bearing frame (19). Make certain that the hex nut portion is pointing toward the bearing frame (19).
14. Locate the flinger (62).
 Frame S does not require a flinger.
 Frame A/LD17 is .86 in. (22 mm) from the radial bearing shoulder with the hub facing the radial bearing. Frame M is 2.0 in. (51 mm) from the retainer cover (35). Tighten the set screws.

Install Rotating Element In Bearing Frame

See Pump Assembly Drawings section 8.0.

1. The rotating element is now ready to install in the bearing frame (19). Lubricate the machined bores inside the bearing frame and the O.D. of the cartridge (33), including the o-ring (405), with oil. Slide the rotating element into the bearing frame.

IMPORTANT:

Make certain that the oil return groove inside the cartridge (33) is located at the 6 o'clock position in the bearing frame (19). The "**blackmer**" logo, which is cast into the outer face of the cartridge, must be at the top. This is important, as it allows the oil to return to the bearing frame through the groove at the bottom of the cartridge, once it has passed through the thrust bearings (18).

2. Mount the cartridge lock nuts (404) onto the cartridge studs (403). Maintain the lock nuts and micrometer nuts (66) in a loose condition to allow a free floating rotating element while the remainder of the pump is being assembled.

3. Press the radial lab seal stator (89D) into the frame adapter (71) if replacement was necessary on the Frame A/LD17 pump. Press in until the face of the stator is flush with the machined tooth in the housing. Make certain that the oil drain slot in the stator is in the 6 o'clock position after the frame adapter is fastened to the bearing frame (19).
4. For the Frame M, fit the labyrinth stator o-ring (89G) onto the radial labyrinth seal stator (89D) and press into the bearing frame (19).
5. Frame S has an integral stator in the bearing housing.
6. Mounting frame adapter
 - a. **Frame S**
Has no separate frame adapter.
 - b. **Frame A/LD17**
Mount the frame adapter (71) onto the bearing frame (19) with o-ring (72) in place and fasten securely.
 - c. **Frame M**
Has a radial labyrinth seal stator which acts as a radial bearing cover and contains an o-ring (89G) to seal the bearing frame.
7. Lubricate the shaft surface with grease or oil to facilitate mounting the thrust labyrinth seal rotor (89B). Mount with two o-rings (89C) on the shaft (6) at the coupling end. Push it all the way into the stator so that the grooves mesh into one another.
8. Lubricate the shaft surface with grease or oil to facilitate mounting the radial labyrinth seal rotor (89E). Mount with two o-rings (89F) on the shaft (6) from the impeller end. Push all the way into the stator so that the grooves mesh into one another.

Install Mechanical Seal

See mechanical seal instructions.

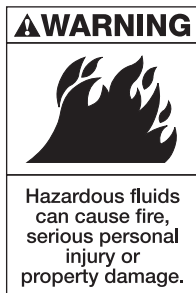

WARNING:
Never operate the pump without liquid supplied to the mechanical seal. Running the mechanical seal dry, even for short periods, can cause seal damage and/or failure. Physical injury can occur if mechanical seal fails.

1. Lubricate the shaft with silicone lubricant. Slide the mechanical seal assembly, including all o-rings and gaskets, over the shaft (6).

Install Back Cover

1. Slide the back cover assembly (11) over the shaft and fasten it to the frame adapter (71) with 2 nuts for Frame S, Frame A 8 in. and 10 in., and Frame M.

The Frame A 13 in. back cover requires 8 nuts. Be sure to remove any paint or debris from the OD of the frame adapter ring.
2. Lightly tighten the mechanical seal gland nuts. These will be snugged later.

Install Impeller

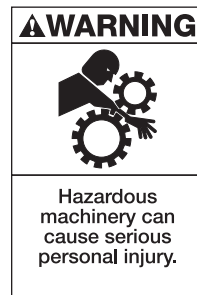

WARNING:
Wear heavy work gloves when handling impeller as sharp edges may cause physical injury.

Fasten the impeller (2) with PTFE o-ring (38) to the shaft (6). Impeller thread should be treated with nickel anti-seize before assembly to prevent galling.

Make sure the impeller hub is fastened hand-tight against the shaft shoulder.

Apply silicone grease to the impeller hub if the pump is an LD17 where the mechanical seal o-ring rides on the impeller hub.

Install Casing

1. Mount the casing (1) to the frame adapter (71). Be sure to insert the gasket (73A) between the casing (1) and the back cover (11). Tighten the casing studs in a crisscross pattern.
2. The 13 in. Frame A/LD17 casing bolts directly to the back cover.
3. Install both feet on the Frame A casing.
4. Mount the entire pump assembly onto the baseplate and securely fasten all the hold down bolts.
5. Attach the suction and discharge piping to the casing (1) while ensuring no strain is imparted to the pump.

NOTE:

The vortex pump has a separate suction cover that can be replaced if necessary.

4.3 Impeller Total Clearance

See Pump Assembly Drawings section 8.0.

It is important to determine whether there is sufficient total impeller clearance within the assembled wet end which includes the casing (1), impeller (2), back cover (11), and suction cover, if applicable.

1. Loosen all three (Frame S and Frame A), or four (Frame M) micrometer nuts (66) and lock nuts (404).
2. Tighten the cartridge lock nuts (404) alternately until the impeller (2) just begins to scrape the suction side of the casing (1). By turning the shaft (6) manually, clockwise facing the coupling, you will hear the impeller scrape the casing bowl. Turn the shaft (6) clockwise only and in complete revolutions between adjustments.
3. Tighten the micrometer nuts (66) alternately, so that they are flush against the cartridge (33). Back off the lock nuts. (404).
4. Turn the micrometer nuts (66) alternately, counting the number of radial lines moving along a fixed point on the cartridge flange. By turning the set of micrometer nuts (66) from one radial line to the next, the impeller (2) will move away from the suction side of the casing (1) by .003 in. (0.08 mm). Continue to do this while rotating the shaft (6) clockwise until the back of the impeller (2) begins to rub the back cover (11).
5. Use the following equation to find the total clearance:

$$\begin{aligned} \text{No. of radial lines} \times .003 \text{ in. (.08 mm)} \\ = \text{total clearance} \end{aligned}$$

The total clearance should fall between .040 in. - .070 in. (1.02 mm - 1.78 mm).

6. If the total clearance needs to be adjusted, proceed as follows:

Change the thickness of the casing gasket (73A) that is located between the casing (1) and the back cover (11). Increasing the gasket thickness will increase the total clearance. If no thicker gasket is on-hand, a second gasket may be installed.

4.4 Impeller Operating Clearance

See Pump Assembly Drawings section 8.0.

The impeller operating clearance is the gap between the impeller blades and the casing bowl. This gap is important in achieving proper performance from the pump.

After the total impeller clearance has been established, set the impeller operating clearance within the pump wet end assembly as follows:

1. Loosen the micrometer nuts (66). For vortex pumps, loosen the cartridge lock nuts (404).
2. Tighten the cartridge lock nuts (404) alternately until the impeller (2) just begins to scrape the casing (1) bowl. Manually turn the shaft (6) clockwise (from coupling end) a complete revolution between adjustments and listen for a scraping sound.

NOTE:

For vortex pumps, the impeller is set off the back cover. Tighten the micrometer nuts evenly until the impeller back vanes just begin to scrape the back cover. The shaft position is set to the opposite face from the standard centrifugal pump instructions indicated above.

3. Tighten the micrometer nuts (66) alternately so that they are flush against the cartridge. Back off the three lock nuts (404) by at least .12 in. (3 mm).

NOTE:

For vortex pumps, tighten the cartridge lock nuts (404).

4. Turn the micrometer nuts (66) alternately, counting the number of radial lines passing a fixed point on the bearing cartridge flange. By turning the micrometer nut from one radial line to the next, the impeller will move by .003 in. (.08 mm). The clearance required between the impeller and the suction side of the casing will vary with the temperature of the liquid being pumped as shown on the following page:

- Up to and including 100°F (38°C), set impeller operating clearance at .015 in. (0.38 mm).
- For every 50°F (28°C) above 100°F (38°C), increase the operating clearance by an additional .002 in. (0.05 mm).
- Remember, each line represents .003 in. (0.08 mm), so a .015 in. (0.38 mm) operating clearance will require you to turn the micrometer nuts (66) five radial lines.

NOTE:

For Vortex pumps, loosen the micrometer nuts (66) approximately 15 lines of .003 in. (.08 mm) each which provides a clearance between the impeller and back cover of .045 in. (1.14 mm).

5. Tighten the lock nuts (404) evenly and alternately against the cartridge (33) flange. Make certain the micrometer nuts (66) do not move while this is being done. Use two wrenches, one to hold the micrometer nut (66) the other to tighten the lock nut (404). For Vortex pumps, tighten the locknuts (404) until the cartridge is tight against the micrometer nuts (66).

4.5 Set Mechanical Seal

After setting the impeller operating clearance, the mechanical seal (80) can be adjusted and securely fastened to the shaft. Tighten mechanical seal gland nuts per the torque specification in section 11. For information on mechanical seal installation, refer to the instructions accompanying the seal.

5.0 Power End Conversions

For information on topics listed below, see appropriate section as noted.

Motor specifications	Section 2.1
Lubrication	Section 2.8
Temperature Control	Section 2.9
Startup Inspection	Section 3.1
Auxiliaries startup	Section 3.2
Disassembly and Assembly procedure	Section 4.1 and 4.2
Impeller clearance	Section 4.3 and 4.4
Mounting the motor	Section 6.0
Auxiliary pipe connections	Section 7.0
Pump assembly drawings	Section 8.0
Recommended spare parts lists	Section 9.0
Pump tolerances	Section 10.0
Fastener torque values	Section 11.0
Ball bearing handling, removal, inspection and installation	Section 12.0
Component inspection	Section 13.0
Troubleshooting	Section 14.0

For the model of conversion indicated, see the appropriate System One model as listed below:

Goulds 3196 ST and Durco MII GRI use Frame S

Goulds 3196 MT (LD23) and Durco MII GR II (LD18) use Frame LD17

Goulds 3196 MT ANSI length and Durco MII GR II ANSI length use Frame A

Goulds 3196 XLT use Frame M

Modifications Required

The base, motor, and coupling may require some modification before proceeding to install the new System One Power End Conversion. Various options are available to use the existing baseplate with the conversion power end.

Please contact the factory if there are any questions regarding the appropriate procedure.

6.0 Mounting The Motor

The pump motor can now be attached to the pump. There are two different methods of mounting the motor. They are as follows:

6.1 Foot Mounted Motor



WARNING:
Pump and components are heavy. Failure to properly lift and support equipment could result in physical injury or damage to the pump. Steel toed shoes should be worn at all times.

In most cases, it will be necessary to install spacer blocks under the motor feet to obtain proper motor support and elevation. Allow for additional space under the motor feet of at least .12 in. (3 mm) for shim stock to allow for proper motor alignment.

A check for soft foot should be performed on the motor feet.

This “Soft Foot Check Procedure” can be used during the initial shimming process or upon completion of the preliminary alignment:

1. Tighten all hold-down bolts or nuts to approximately fifty percent of torque value on the unit (pump and motor) to be shimmed.
2. Secure a dial indicator base to the pump baseplate, or suitable surface. The dial indicator stem is placed vertically on the top edge of the foot to be checked. Zero the dial indicator. Completely loosen the hold-down bolts or nuts on that foot only. Watch dial indicator for foot movement during the loosening process.
3. If the foot rises from the base when the hold-down bolts or nuts are loosened, place shim stock equal to the amount of deflection shown on the dial indicator under the foot. Soft foot readings less than or equal to .005 in. (0.13 mm) require no corrections.

4. Tighten the hold-down bolt or nut and repeat the entire process until no movement is present.
5. Move the dial indicator to the next foot and repeat the above process.
6. Repeat until all feet have been checked and corrected as necessary.

Remember:
All other feet must remain securely tightened when a foot is being checked for soft foot.

6.2 Coupling

Install a spacer type coupling between the pump and motor. The pump and motor are now ready for alignment.

Shaft gaps are as follows for pumps not using motor adapters:

Frame S and Frame A	3.63 in. (92 mm)
Frame M	5.25 in. or 7.25 in. (133 mm) or (184 mm)

6.3 Motor Mounted on C-Frame or D-Flange Motor Adapter

Wiring the motor with flexible conduit will allow simple removal of the power end when servicing the pump.

NOTICE:
The coupling end of the pump bearing frame has a male fit for mounting the motor adapter which must be cleaned to bare metal. Remove all the paint and debris from the radial fit and the face fit surfaces. Failure to do so will result in poor coupling alignment.

NOTE:
 The C-frame (NEMA) or D-flange (IEC) motor adapter (optional items) do not require coupling alignment.

1. Attach the motor adapter to the pump bearing frame (19). Be sure to alternately tighten the bolts to maintain correct alignment.
2. Install the coupling hubs on the pump and motor shafts.

3. Fasten the pump feet to the baseplate.
4. Bolt motor to motor adapter.
Use a lifting device to support the motor while attaching to the motor adapter. If there is a small gap between the motor feet and the support blocks, it must be completely filled with shims while the motor is supported by the lifting device. This will prevent motor adapter distortion that could result in shaft misalignment.
5. After shimming, remove the motor support and fasten the motor feet to the mounting blocks.
6. Motor frames 140 to 210TC weighing less than 183 lb (83 kg) can be suspended from the C-frame adapter without additional support.
7. Motor frames 250TC weighing up to 309 lb. (140 kg) can be supported by support feet (available from the factory) under the two rear motor feet (except Frame S which requires 1 in. (25 mm) pads under the pump).
8. Motor frames 280TC and up, weighing more than 309 lb. (140 kg) must be supported by and bolted to solid pads under all four feet.

NOTICE:

Large motors may result in a slight deflection of the C-frame adapter. Failure to follow this procedure below may result in damage to pump and/or motor during operation.

To insure proper alignment of motor and pump shafts, the following procedures should be followed:

- Externally mount a dial indicator arranged to read from C-frame adapter flange on motor end. Zero indicator once it is in place.
 - Mount motor to C-frame adapter, noting any changes to indicator reading.
 - a. If no change occurs, insert shims between motor feet and motor pads before securing motor. Check “soft foot” per section 6.1.
 - b. If the indicator reading shows movement, the motor must be lifted and shimmed until the indicator reading returns to zero. After inserting shims between motor feet and motor pads, check “soft foot” per section 6.1.
 - Fully torque all motor hold-down bolts before operating motor.
9. Assemble and lubricate the coupling as required by the coupling manufacturer. Coupling alignment is unnecessary.
 10. Install coupling guard.



WARNING:
Never operate pump without coupling guard properly installed. Personal injury can occur if pump is operated without coupling guard.

C-Frame Motor Adapter Selection Chart

Motor Frame	Frame S	Frame A	Frame M
143 – 215TC	C-Frame	Small C-Frame	
254 – 256TC	Requires motor spacer	Small C-Frame w/motor spacer and foot supports	
284 – 286T(S)C	Requires motor spacer	Large C-Frame	Small C-Frame
324 – 326T(S)C	Requires motor spacer	Large C-Frame	Small C-Frame
364 – 365TC		Large C-Frame w/motor spacer	Small C-Frame
364 – 405TSC		Large C-Frame w/motor spacer	
444 – 445TSC		Large C-Frame w/motor spacer	
404 – 449TC			Large C-Frame

7.0 Auxillary Pipe Connections List

7.1 Auxillary Pipe Connections List - Frame S

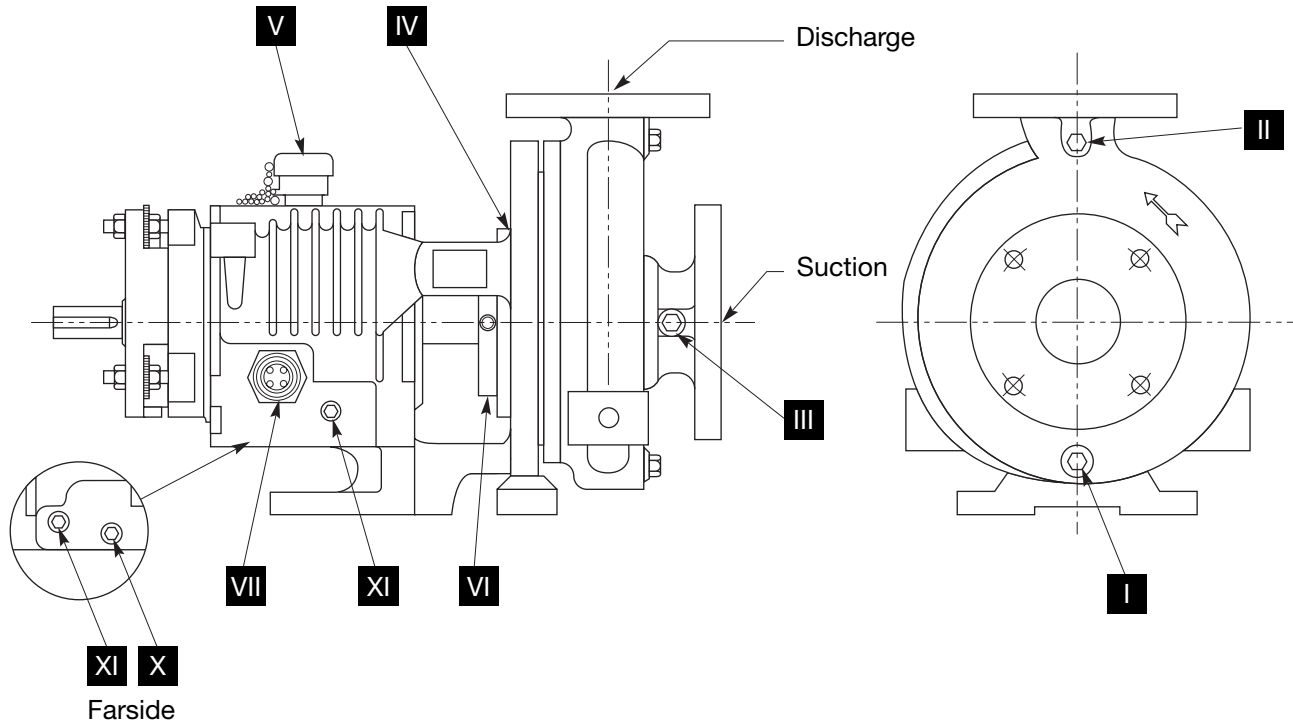

Item Number	NPT Sizes	Number Of Taps	Connection
* I	0.38 - 18	1	Casing Drain
II	0.25 - 18	1	Discharge Gage
III	0.25 - 18	1	Suction Gage
IV	0.12 - 27	1	Seal Chamber Flush
V	0.75 - 14	1	Oil Fill
* VI	0.25 - 18 & 0.12 - 27	2	Seal Chamber Jacket - Inlet/Outlet
# VII	0.75 - 14	1	Oil Sight Glass
## X	0.25 - 18	1	Oil Drain or Temperature Monitor
XI	0.25 - 18	2	Magnetic Plug or Cooling Coil*

* Optional
 # Left side of pump facing suction end
 ## Right side of pump facing suction end

7.2 Auxiliary Pipe Connections List - Frame A and LD17

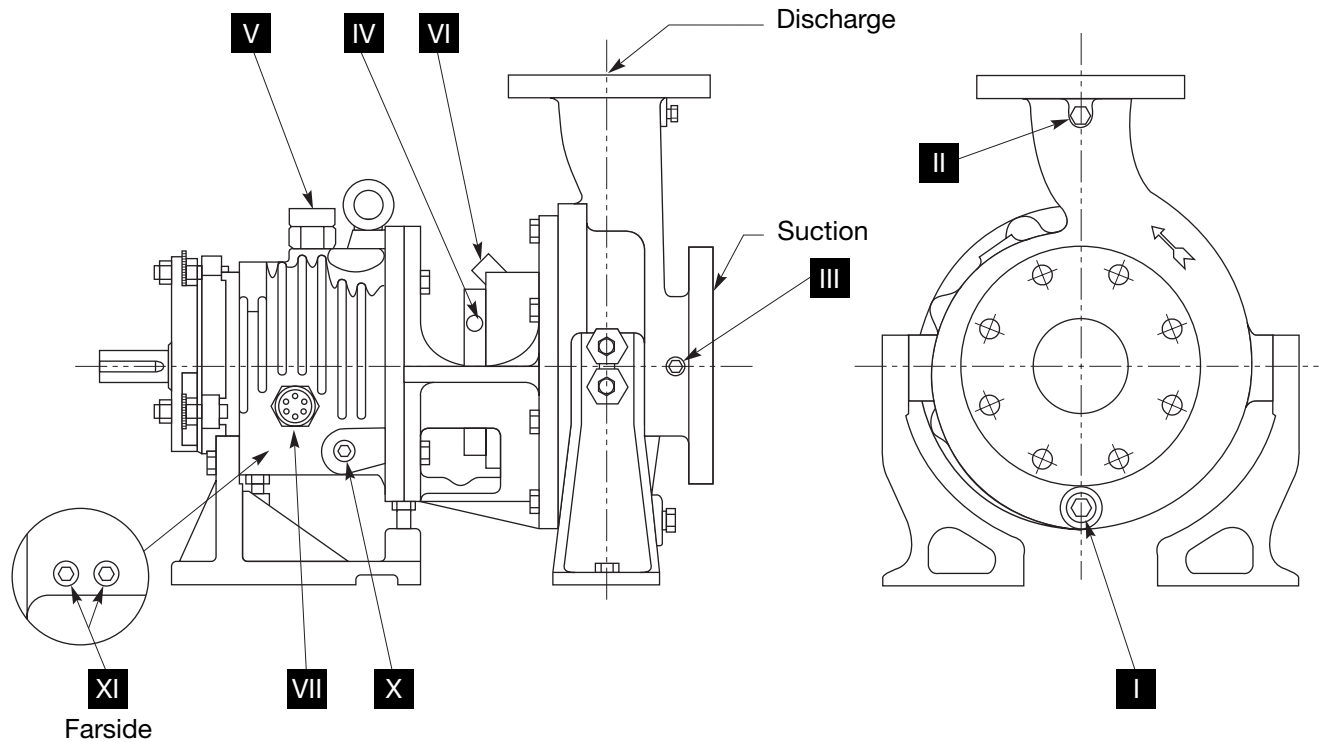

Item Number	NPT Sizes	Number Of Taps	Connection
* I	0.50 - 14	1	Casing Drain
II	0.25 - 18	1	Discharge Gage
# III	0.25 - 14	1	Suction Gage
* IV	0.25 - 18	1	Seal Chamber Flush (not available on LD17)
V	0.75 - 14	1	Oil Fill
VI	0.25 - 18	2	Seal Chamber Jacket* - Inlet/Outlet (not available on LD17)
# VII	1.00 - 11.5	1	Oil Sight Glass
# X	0.75 - 14	1	Oil Drain or Temperature Monitor
## XI	0.50 - 14	2	Magnetic Plug or Cooling Coil*

* Optional

Left side of pump facing suction end

Right side of pump facing suction end

(4 x 6 - 10 and 4 x 6 - 13 Casings have discharge tap only)

7.3 Auxiliary Pipe Connections List - Vortex, Frame A and LD17

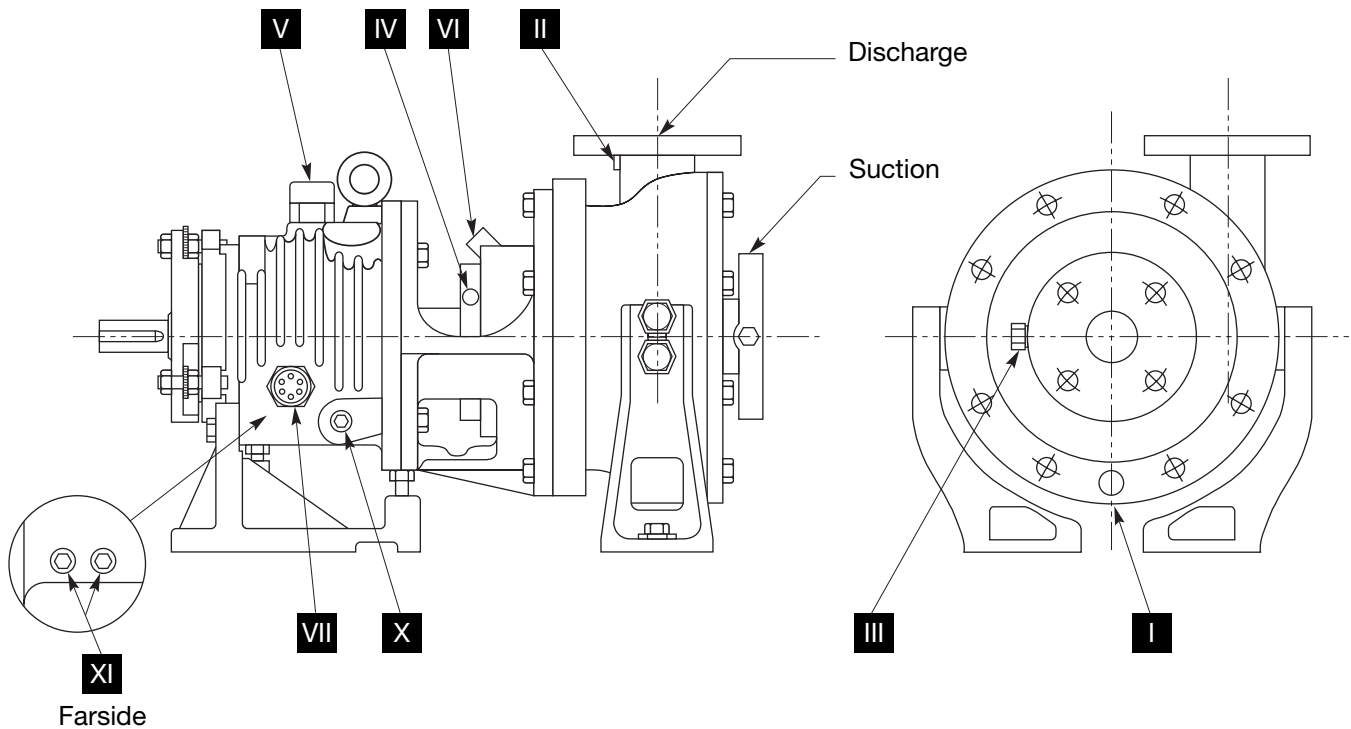

Item Number	NPT Sizes	Number Of Taps	Connection
* I	0.50 - 14	1	Casing Drain
* II	0.25 - 18	1	Discharge Gage
* IV	0.25 - 18	1	Seal Chamber Flush (not available on LD17)
V	0.75 - 14	1	Oil Fill
* VI	0.25 - 18	2	Seal Chamber Jacket* - Inlet/Outlet (not available on LD17)
# VII	1.00 - 11.5	1	Oil Sight Glass
# X	0.75 - 14	1	Oil Drain or Temperature Monitor
## XI	0.50 - 14	2	Magnetic Plug or Cooling Coil*

* Optional
 # Left side of pump facing suction end
 ## Right side of pump facing suction end

7.4 Auxiliary Pipe Connections List - Frame M

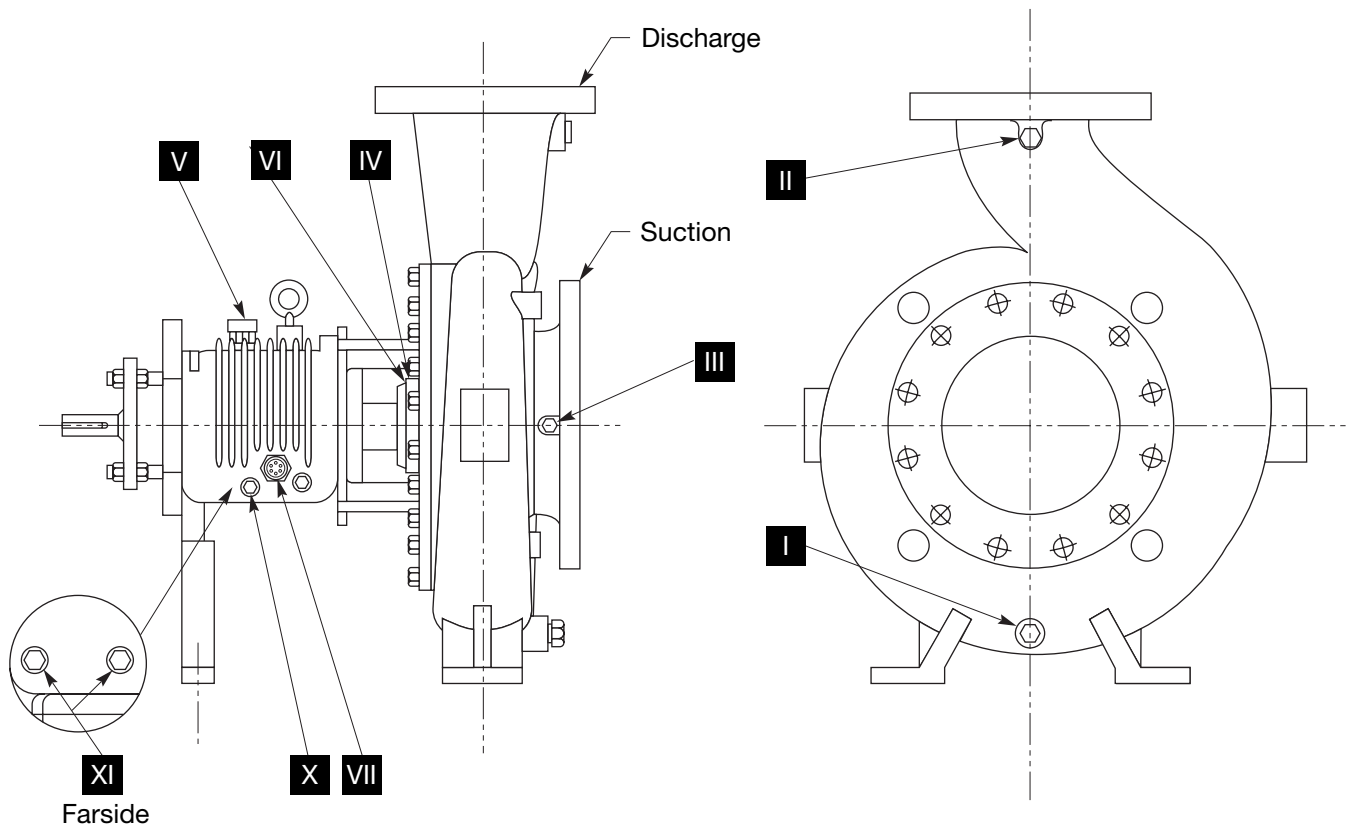

Item Number	NPT Sizes	Number Of Taps	Connection
I	0.50 - 14	1	Casing Drain
II	0.25 - 18	1	Discharge Gage
* III	0.25 - 18	1	Suction Gage
IV	0.50 - 14	2	Seal Chamber Flush
V	0.75 - 14	1	Oil Fill
* VI	0.50 - 14	2	Seal Chamber Jacket - Inlet/Outlet
# VII	1.00 - 11.5	1	Oil Sight Glass
# X	0.50 - 14	1	Oil Drain or Temperature Monitor
## XI	0.50 - 14	2	Plug or Cooling Coil*

* Optional
 # Left side of pump facing suction end
 ## Right side of pump facing suction end

8.0 Pump Assembly Drawings and Parts List

8.1 Pump Assembly & Parts List - Frame S Horizontal 6"

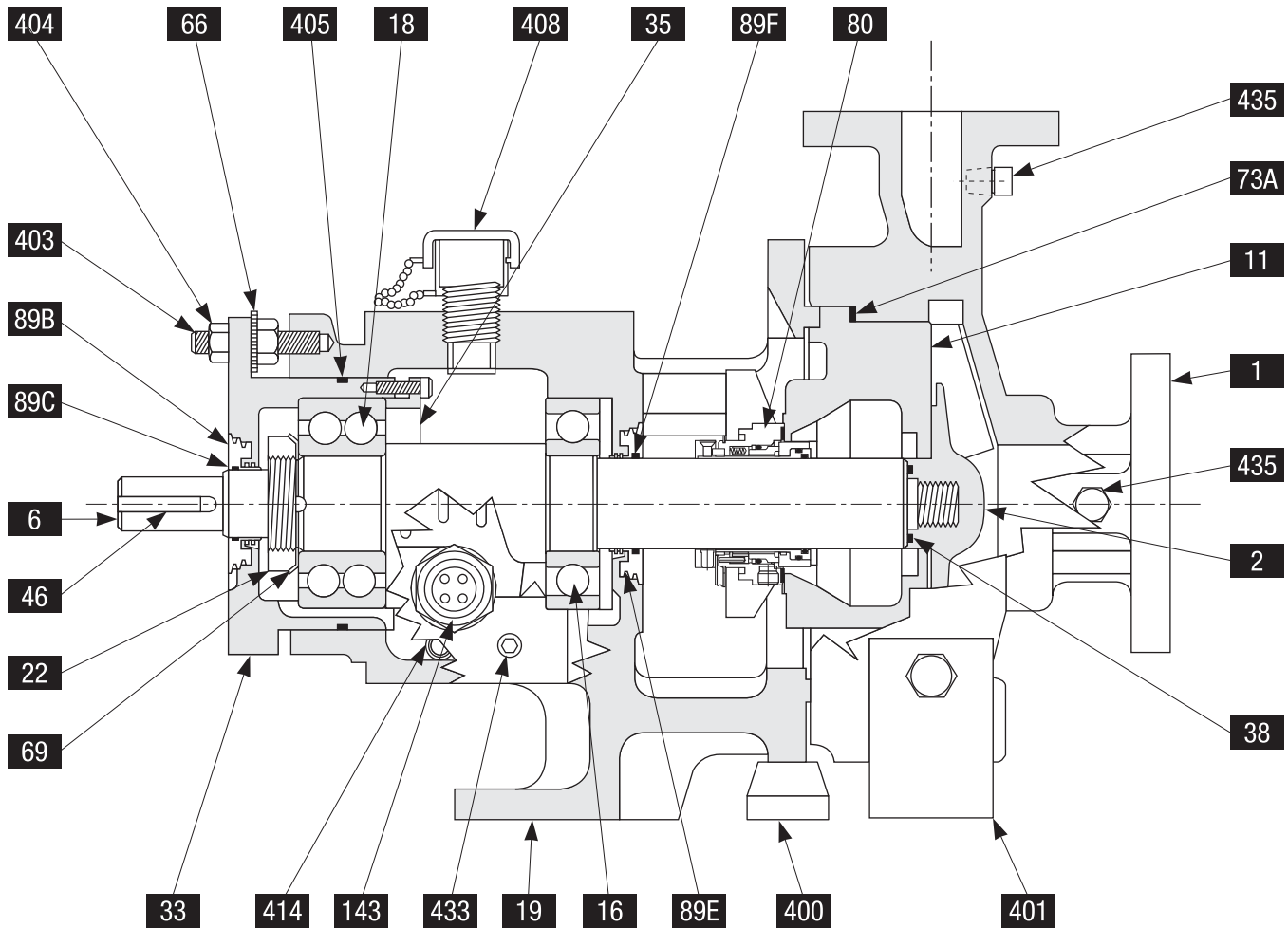

No.	Item	No.	Item	No.	Item
1	Casing	66	Micrometer Nut	404	Locknut, Cartridge
2	Impeller	69	Lockwasher, Thrust Bearing	405	O-Ring, Cartridge
6	Shaft	73A	Gasket, Casing	408	Oil Filler Assembly
11	Back Cover	80	Mechanical Seal	414	Plug, Magnetic
16	Bearing, Radial	89E	Seal, Labyrinth Rotor, Radial	433	Plug, Bearing Frame
18	Bearing, Thrust	89F	Seal, Labyrinth O-Ring, Radial	435	Plug, Casing
19	Bearing Frame	89B	Seal, Labyrinth Rotor, Thrust		
22	Locknut, Thrust Bearing	89C	Seal, Labyrinth O-Ring, Thrust		
33	Bearing Cartridge	143	Oil Sight Glass		
35	Retainer Cover	400	Foot, Bearing Frame		
38	O-Ring, Impeller Hub	401	Foot, Casing (optional)		
46	Key, Coupling	403	Stud, Cartridge		

8.2 Pump Assembly & Parts List - Frame S Horizontal 8"

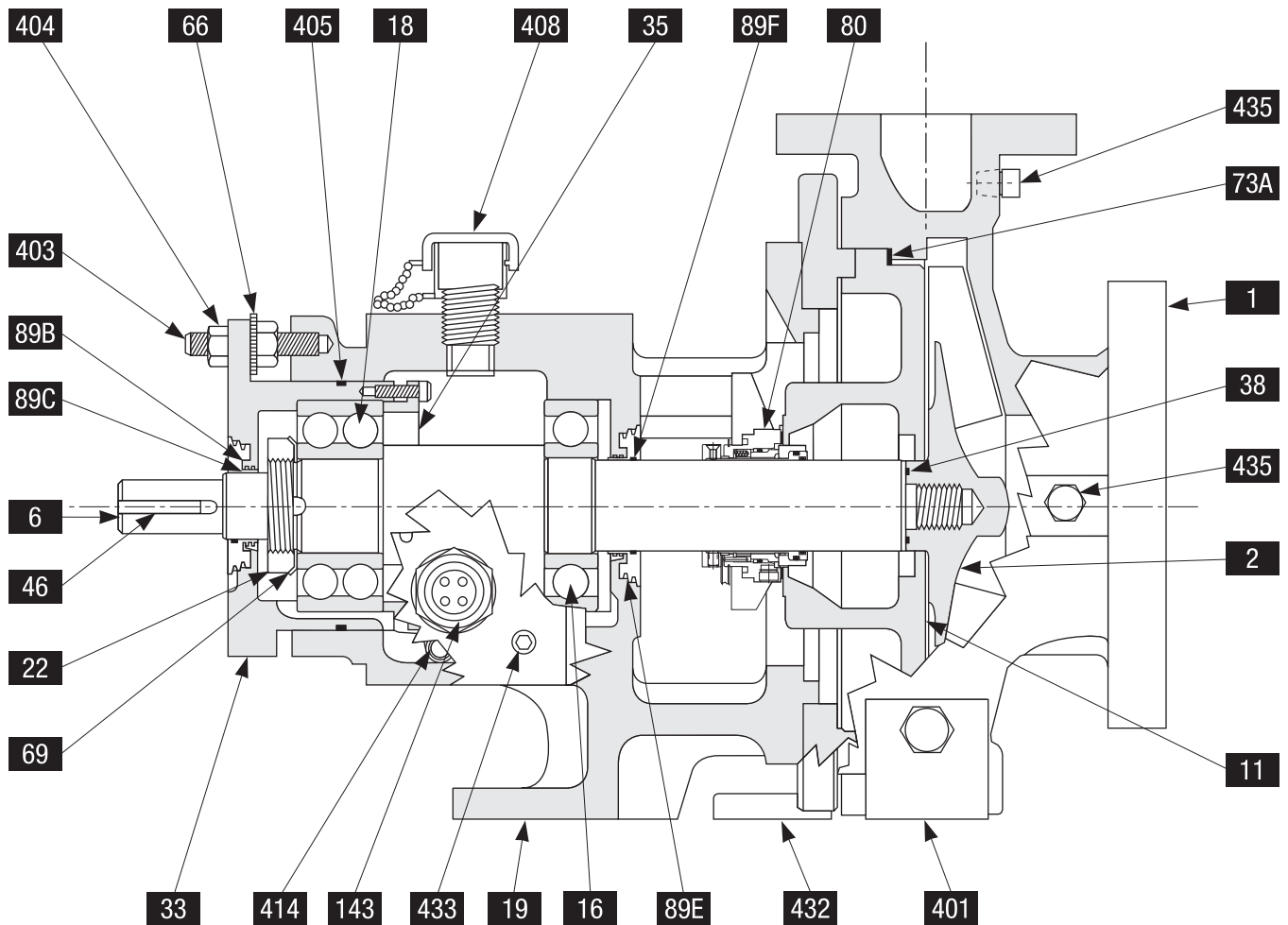

No.	Item	No.	Item	No.	Item
1	Casing	66	Micrometer Nut	404	Locknut, Cartridge
2	Impeller	69	Lockwasher, Thrust Bearing	405	O-Ring, Cartridge
6	Shaft	73A	Gasket, Casing	408	Oil Filler Assembly
11	Back Cover	80	Mechanical Seal	414	Plug, Magnetic
16	Bearing, Radial	89E	Seal, Labyrinth Rotor, Radial	432	Adapter Plate
18	Bearing, Thrust	89F	Seal, Labyrinth O-Ring, Radial	433	Plug, Bearing Frame
19	Bearing Frame	89B	Seal, Labyrinth Rotor, Thrust	435	Plug, Casing
22	Locknut, Thrust Bearing	89C	Seal, Labyrinth O-Ring, Thrust		
33	Bearing Cartridge	143	Oil Sight Glass		
35	Retainer Cover	400	Foot, Bearing Frame		
38	O-Ring, Impeller Hub	401	Foot, Casing (optional)		
46	Key, Coupling	403	Stud, Cartridge		

8.3 Pump Assembly & Parts List - Frame A

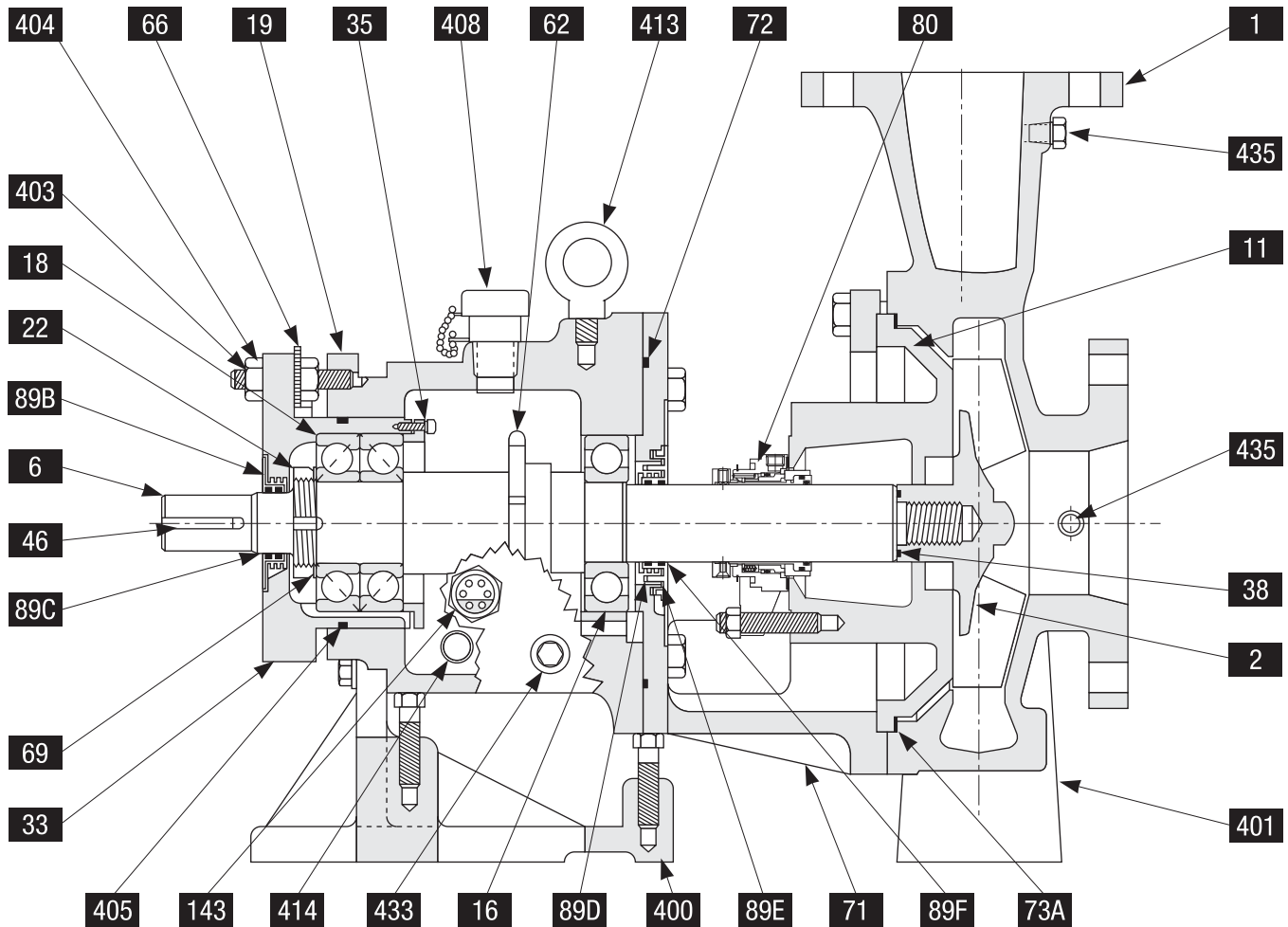

No.	Item	No.	Item	No.	Item
1	Casing	62	Flinger	143	Oil Sight Glass
2	Impeller	66	Micrometer Nut	400	Foot, Bearing Frame
6	Shaft	69	Lockwasher, Thrust Bearing	401	Foot, Casing
11	Back Cover	71	Frame Adapter	403	Stud, Cartridge
16	Bearing, Radial	72	O-Ring Frame Adapter	404	Locknut, Cartridge
18	Bearing, Thrust	73A	Gasket, Casing	405	O-Ring, Cartridge
19	Bearing Frame	80	Mechanical Seal	408	Oil Filler Assembly
22	Locknut, Thrust Bearing	89B	Seal, Labyrinth Rotor, Thrust	413	Bolt, Eye
33	Bearing Cartridge	89C	Seal, Labyrinth O-Ring, Thrust	414	Pipe Plug, Magnetic
35	Retainer Cover	89D	Seal, Labyrinth Stator, Radial	433	Pipe Plug, Bearing Frame
38	O-Ring, Impeller Hub	89E	Seal, Labyrinth Rotor, Radial	435	Pipe Plug, Casing
46	Key, Coupling	89F	Seal, Labyrinth O-Ring, Radial		

8.4 Pump Assembly & Parts List - LD17

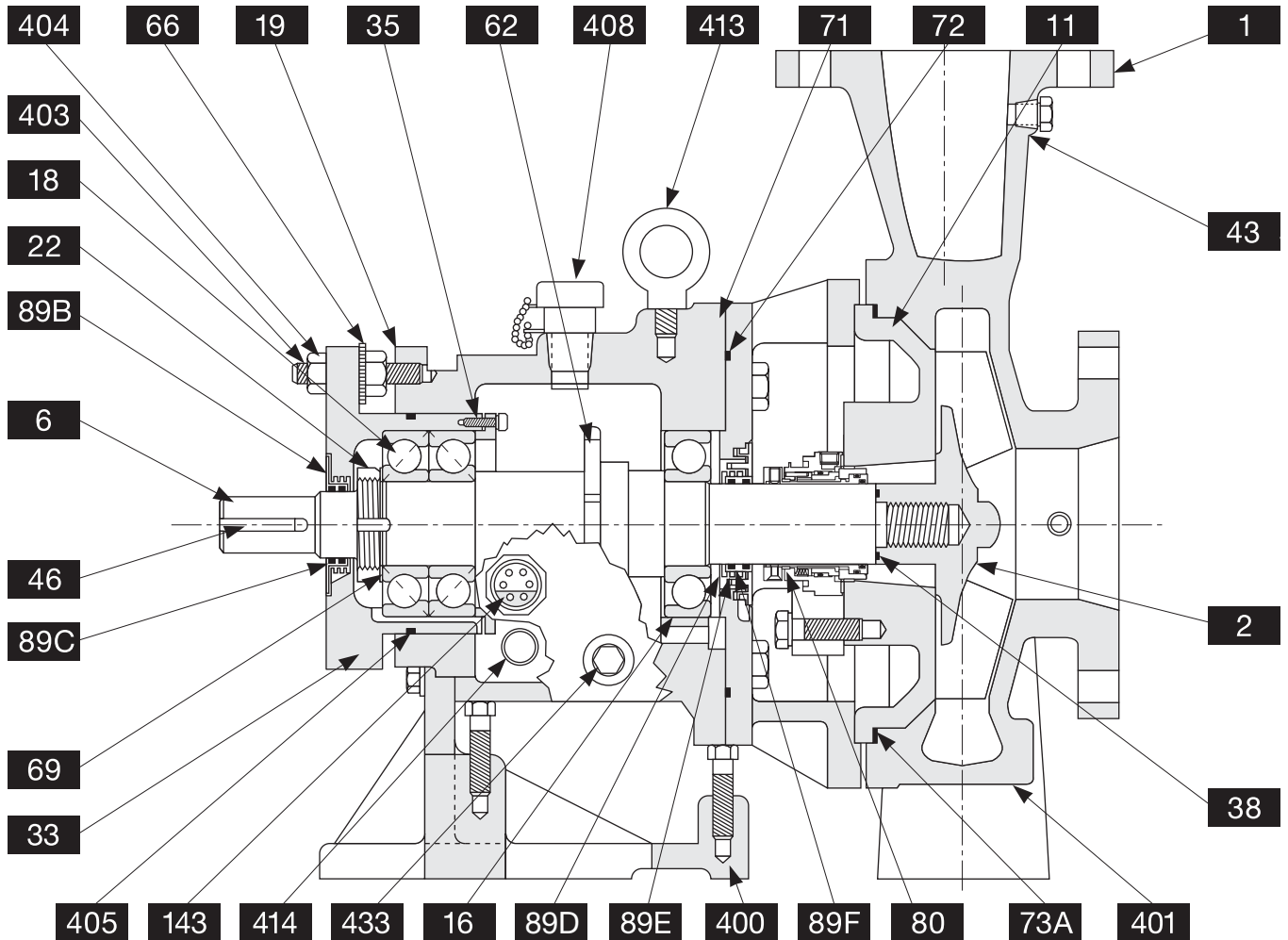

No.	Item	No.	Item	No.	Item
1	Casing	62	Flinger	143	Oil Sight Glass
2	Impeller	66	Micrometer Nut	400	Foot, Bearing Frame
6	Shaft	69	Lockwasher, Thrust Bearing	401	Foot, Casing
11	Back Cover	71	Frame Adapter	403	Stud, Cartridge
16	Bearing, Radial	72	O-Ring Frame Adapter	404	Locknut, Cartridge
18	Bearing, Thrust	73A	Gasket, Casing	405	O-Ring, Cartridge
19	Bearing Frame	80	Mechanical Seal	408	Oil Filler Assembly
22	Locknut, Thrust Bearing	89B	Seal, Labyrinth Rotor, Thrust	413	Bolt, Eye
33	Bearing Cartridge	89C	Seal, Labyrinth O-Ring, Thrust	414	Pipe Plug, Magnetic
35	Retainer Cover	89D	Seal, Labyrinth Stator, Radial	433	Pipe Plug, Bearing Frame
38	O-Ring, Impeller Hub	89E	Seal, Labyrinth Rotor, Radial	435	Pipe Plug, Casing
46	Key, Coupling	89F	Seal, Labyrinth O-Ring, Radial		

8.5 Pump Assembly & Parts List - Vortex, Frame A

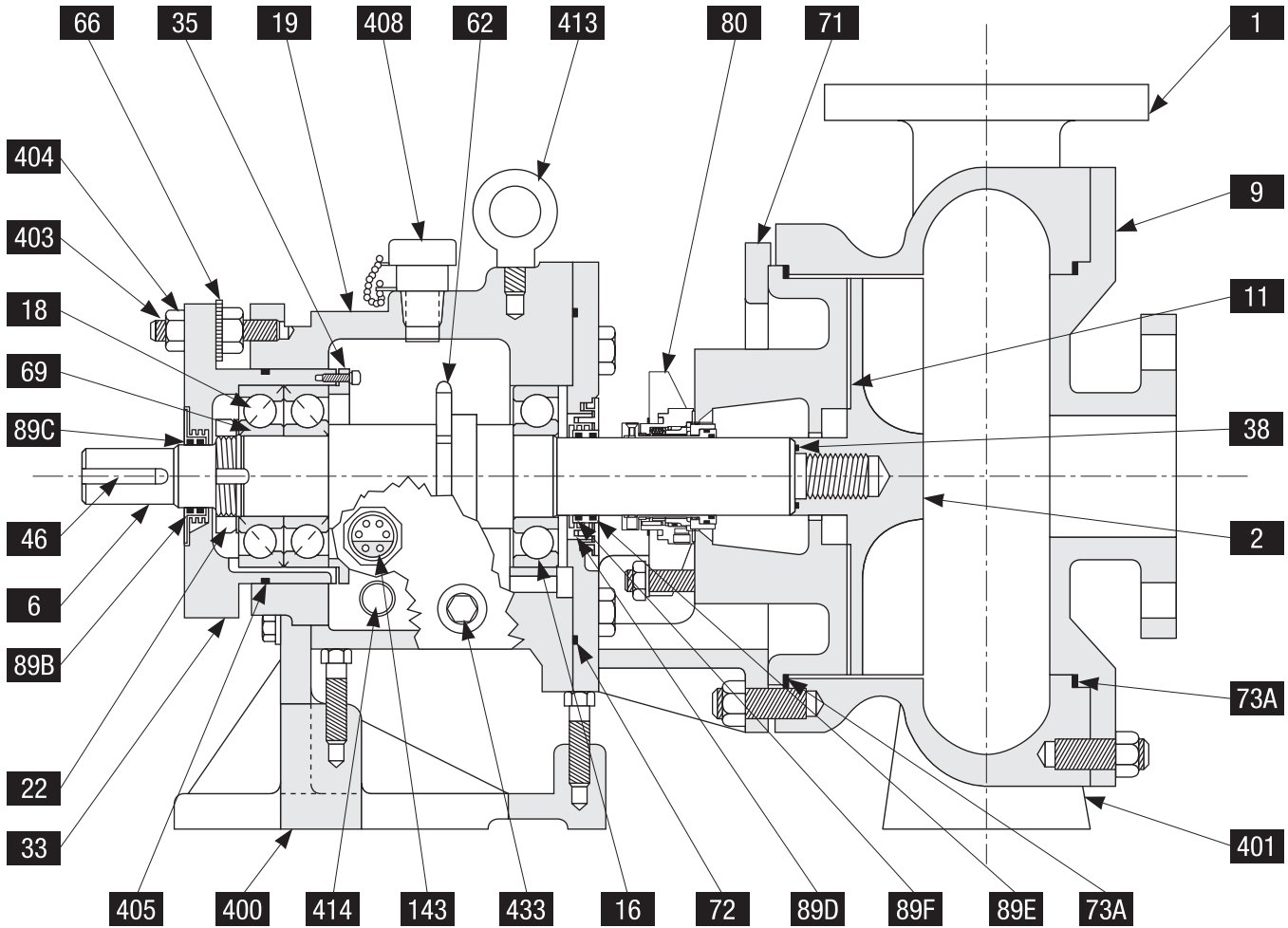

No.	Item	No.	Item	No.	Item
1	Casing	46	Key, Coupling	89F	Seal, Labyrinth O-Ring, Radial
2	Impeller	62	Flinger	143	Oil Sight Glass
6	Shaft	66	Micrometer Nut	400	Foot, Bearing Frame
9	Suction Cover	69	Lockwasher, Thrust Bearing	401	Foot, Casing
11	Back Cover	71	Frame Adapter	403	Stud, Cartridge
16	Bearing, Radial	72	O-Ring Frame Adapter	404	Locknut, Cartridge
18	Bearing, Thrust	73A	Gasket, Casing	405	O-Ring, Cartridge
19	Bearing Frame	80	Mechanical Seal	408	Oil Filler Assembly
22	Locknut, Thrust Bearing	89B	Seal, Labyrinth Rotor, Thrust	413	Bolt, Eye
33	Bearing Cartridge	89C	Seal, Labyrinth O-Ring, Thrust	414	Plug, Magnetic
35	Retainer Cover	89D	Seal, Labyrinth Stator, Radial	433	Plug, Bearing Frame
38	O-Ring, Impeller Hub	89E	Seal, Labyrinth Rotor, Radial		

8.6 Pump Assembly & Parts List - Vortex, LD17

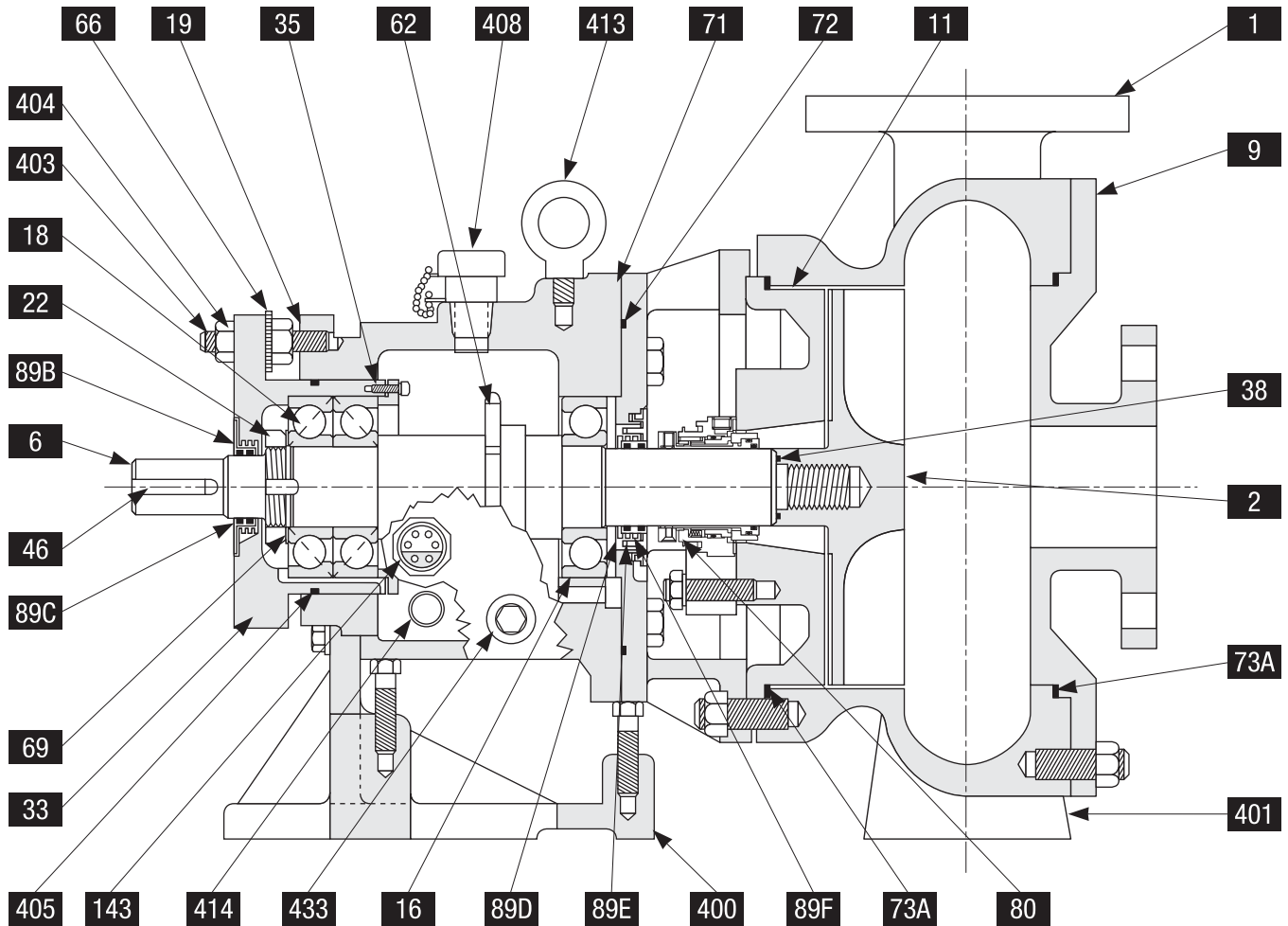

No.	Item	No.	Item	No.	Item
1	Casing	46	Key, Coupling	89F	Seal, Labyrinth O-Ring, Radial
2	Impeller	62	Flinger	143	Oil Sight Glass
6	Shaft	66	Micrometer Nut	400	Foot, Bearing Frame
9	Suction Cover	69	Lockwasher, Thrust Bearing	401	Foot, Casing
11	Back Cover	71	Frame Adapter	403	Stud, Cartridge
16	Bearing, Radial	72	O-Ring Frame Adapter	404	Locknut, Cartridge
18	Bearing, Thrust	73A	Gasket, Casing	405	O-Ring, Cartridge
19	Bearing Frame	80	Mechanical Seal	408	Oil Filler Assembly
22	Locknut, Thrust Bearing	89B	Seal, Labyrinth Rotor, Thrust	413	Bolt, Eye
33	Bearing Cartridge	89C	Seal, Labyrinth O-Ring, Thrust	414	Plug, Magnetic
35	Retainer Cover	89D	Seal, Labyrinth Stator, Radial	433	Plug, Bearing Frame
38	O-Ring, Impeller Hub	89E	Seal, Labyrinth Rotor, Radial		

8.8A Outline and Pump Dimensions - Frame M and S

Frame M

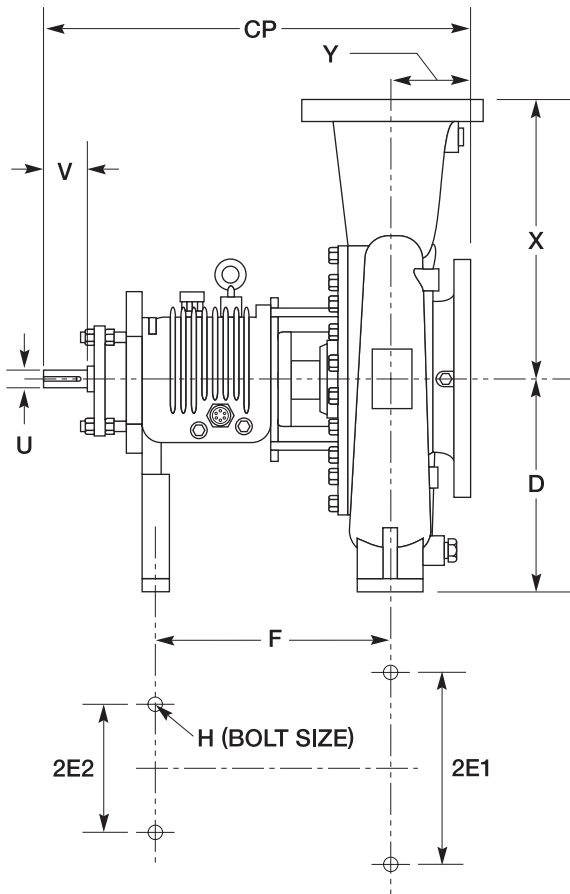

Frame S

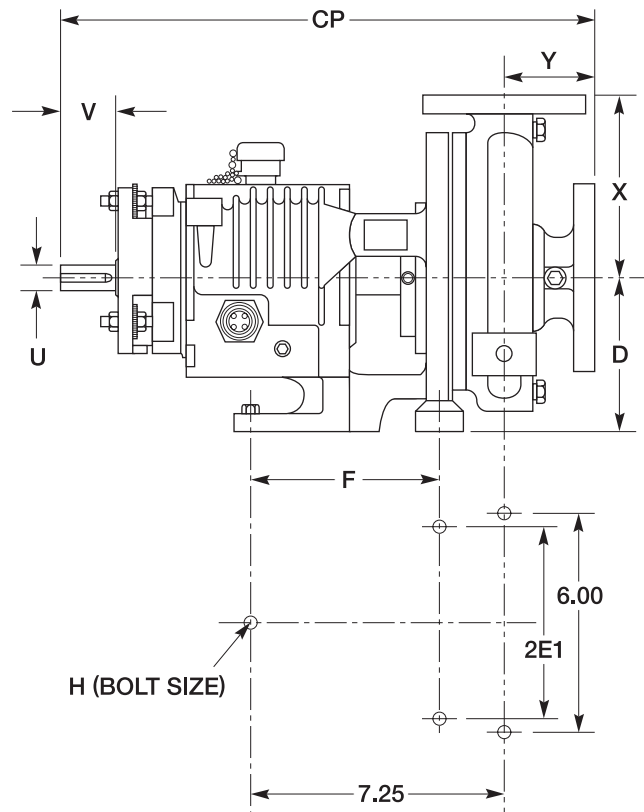

Frame	Pump	Dischrg. Size	Suction Size	Nom. Max. Imp. Dia.	X	D	2E ₁	2E ₂	Y	U	V	CP	F	H	Wt.
M	6 x 8 - 13	6	8	13	16.00	14.50	16.00	9.00	6.00	2.38	4.00	33.88	18.75	.75 - 10UNC	545
	8 x 10 - 13	8	10	13	18.00	14.50	16.00	9.00	6.00	2.38	4.00	33.88	18.75	.75 - 10UNC	657
	6 x 8 - 15	6	8	15	18.00	14.50	16.00	9.00	6.00	2.38	4.00	33.88	18.75	.75 - 10UNC	618
	8 x 10 - 15	8	10	15	19.00	14.50	16.00	9.00	6.00	2.38	4.00	33.88	18.75	.75 - 10UNC	730
	4 x 6 - 17	4	6	17	16.00	14.50	16.00	9.00	6.00	2.38	4.00	33.88	18.75	.75 - 10UNC	N/A
	6 x 8 - 17	6	8	17	18.00	14.50	16.00	9.00	6.00	2.38	4.00	33.88	18.75	.75 - 10UNC	N/A
	8 x 10 - 17	8	10	17	19.00	14.50	16.00	9.00	6.00	2.38	4.00	33.88	18.75	.75 - 10UNC	N/A
S	1 x 1.5 - 6	1	1.5	6	6.50	5.25	5.50	N/A	4.00	0.875	1.75	17.50	4.88	.50 - 13UNC	105
	2 x 3 - 6	2	3	6	6.50	5.25	5.50	N/A	4.00	0.875	1.75	17.50	4.88	.50 - 13UNC	118
	1 x 1.5 - 8	1	1.5	8	6.50	5.25	7.50	N/A	4.00	0.875	1.75	17.50	4.25	.50 - 13UNC	111
	1.5 x 3 - 8	1.5	3	8	6.50	5.25	7.50	N/A	4.00	0.875	1.75	17.50	4.25	.50 - 13UNC	121

8.8B Outline and Pump Dimensions - Frame A and LD17

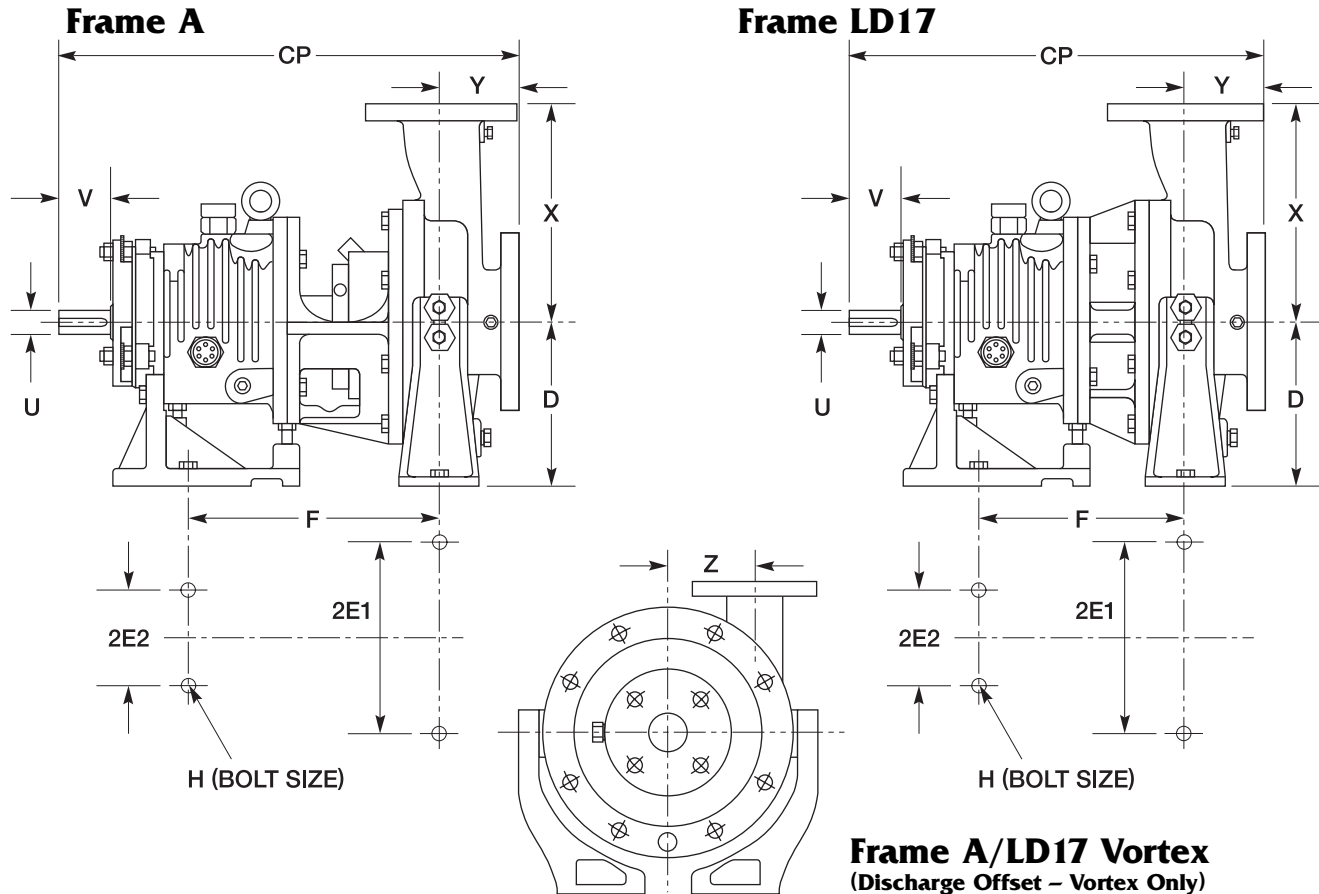

Frame	Pump	Dischrg. Size	Suction Size	Nom. Max. Imp. Dia.	X	D	2E ₁	2E ₂	Y	U	V	CP	F	H	Z	Wt.
A LD17	2 x 3 - 8	2	3	8	9.50	8.25	9.75	7.25	4.00	1.375	2.19	23.50* 20.81	12.50	.50 - 13UNC	N/A	258
	3 x 4 - 8	3	4	8	11.00	8.25	9.75	7.25	4.00	1.375	2.19			.50 - 13UNC	N/A	268
	1 x 2 - 10	1	2	10	8.50	8.25	9.75	7.25	4.00	1.375	2.19			.50 - 13UNC	N/A	244
	1.5 x 3 - 10	1.5	3	10	8.50	8.25	9.75	7.25	4.00	1.375	2.19			.50 - 13UNC	N/A	259
	2 x 3 - 10	2	3	10	9.50	8.25	9.75	7.25	4.00	1.375	2.19			.50 - 13UNC	N/A	268
	3 x 4 - 10	3	4	10	11.00	8.25	9.75	7.25	4.00	1.375	2.19			.50 - 13UNC	N/A	278
	4 x 6 - 10	4	6	10	13.50	10.00	9.75	7.25	4.00	1.375	2.19			.50 - 13UNC	N/A	318
	1.5 x 3 - 13	1.5	3	13	10.50	10.00	9.75	7.25	4.00	1.375	2.19			.50 - 13UNC	N/A	338
	2 x 3 - 13	2	3	13	11.50	10.00	9.75	7.25	4.00	1.375	2.19			.50 - 13UNC	N/A	359
	3 x 4 - 13	3	4	13	12.50	10.00	13.00	7.25	4.00	1.375	2.19			.50 - 13UNC	N/A	374
4 x 6 - 13	4	6	13	13.50	10.00	13.00	7.25	4.00	1.375	2.19	.50 - 13UNC	N/A	401			
VORTEX A LD17	2 x 2 - 8	2	2	8	7.75	8.25	7.50	7.25	4.00	1.375	2.19	26.03*	14.73	.50 - 13UNC	4.37	302
	2 x 2 - 8	2	2	8	7.75	8.25	7.50	7.25	4.00	1.375	2.19	23.34	14.73	.50 - 13UNC	4.37	302
	3 x 3 - 10	3	3	10	9.50	10.00	7.12	7.25	4.62	1.375	2.19	27.19*	15.62	.50 - 13UNC	5.50	357
	3 x 3 - 10	3	3	10	9.50	10.00	7.12	7.25	4.62	1.375	2.19	24.50	15.62	.50 - 13UNC	5.50	357
	4 x 4 - 12	4	4	12	11.50	10.00	9.88	7.25	5.50	1.375	2.19	29.37*	16.88	.50 - 13UNC	6.50	470
4 x 4 - 12	4	4	12	11.50	10.00	9.88	7.25	5.50	1.375	2.19	26.68	16.88	.50 - 13UNC	6.50	470	

* Dimension applies to Frame A.

8.9 Outline and Base Plate Dimensions - Frame S, A, LD17 and M

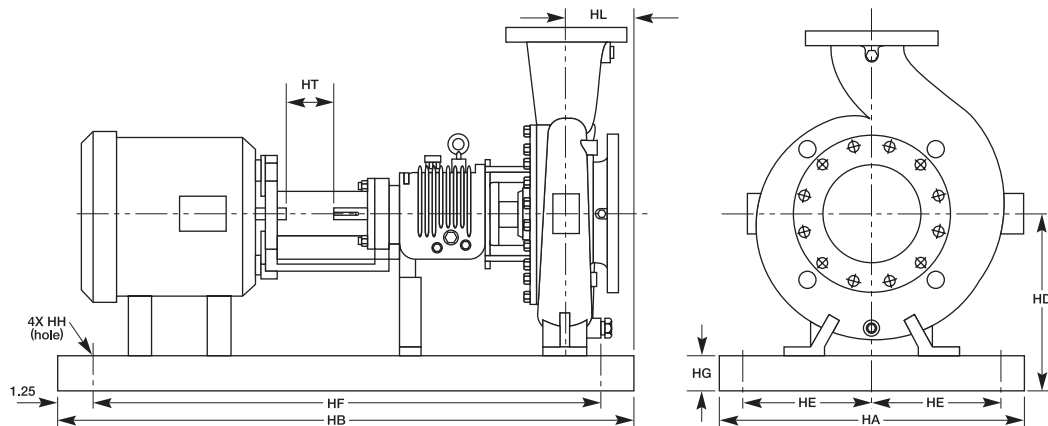

Frame	Motor	HA	HB	HD**	Dimension HT For Frame Type			HG	HE	HF	HH	HL
					T/TS	TC	TSC					
S	56	12.00	36.00	8.25	3.63	N/A	N/A	3.00	4.50	33.50	0.75	4.75
	143/145	12.00	42.00	8.25	3.63	N/A	N/A	3.00	4.50	39.50	0.75	4.75
	56	12.00	42.00	8.25	N/A	1.15	N/A	3.00	4.50	39.50	0.75	4.75
	143/145	12.00	42.00	8.25	N/A	1.09	N/A	3.00	4.50	39.50	0.75	4.75
	182/184	12.00	42.00	8.25	3.63	0.75	N/A	3.00	4.50	39.50	0.75	4.75
	213/215	12.00	42.00	8.25	3.63	0.25	N/A	3.00	4.50	39.50	0.75	4.75
	254/256	15.00	48.00	9.75	3.63	0.49	N/A	3.50	6.00	45.50	0.75	4.50
	284/286	15.00	48.00	10.50	3.75	N/A	N/A	3.50	6.00	45.50	0.75	4.50
	284/286	18.00	52.00	11.00	N/A	N/A	1.53	4.00	7.50	49.50	1.00	4.75
A LD17	143/145	18.00	45.00	12.25 or 14.00*	3.63	0.63	N/A	4.00	7.50	42.50	1.00	4.50
	182/184	18.00	45.00		3.63	0.63	N/A	4.00	7.50	42.50	1.00	4.50
	213/215	18.00	52.00		3.63	0.13	N/A	4.00	7.50	49.50	1.00	4.50
	254/256	18.00	58.00		3.63	0.38	N/A	4.00	7.50	55.50	1.00	4.50
	284/286	18.00	58.00		3.63	0.63	2.00	4.00	7.50	55.50	1.00	4.50
	324/326	18.00	64.00	3.63	0.38	1.88	4.00	7.50	61.50	1.00	4.50	
	364/365	18.00	64.00	14.00	3.63	0.34	1.88	4.00	7.50	61.50	1.00	4.50
	404/405	24.00	68.00	14.88	3.63	N/A	1.38	4.25	9.50	65.50	1.00	4.50
	444/445	26.00	80.00	15.88	3.63	N/A	1.88	4.25	9.50	77.50	1.00	4.50
	447/449	26.00	80.00	15.88	3.63	N/A	1.88	4.25	9.50	77.50	1.00	4.50
VORTEX A LD17	143/145	18.00	52.00	12.25 or 14.00*	3.63	0.63	N/A	4.00	7.50	49.50	1.00	2 x 2 - 8 = 8.15 3 x 3 - 10 = 7.25 4 x 4 - 12 = 6.00
	182/184	18.00	52.00		3.63	0.63	N/A	4.00	7.50	49.50	1.00	
	213/215	18.00	58.00		3.63	0.13	N/A	4.00	7.50	55.50	1.00	
	254/256	18.00	58.00		3.63	N/A	N/A	4.00	7.50	55.50	1.00	
	254/256	18.00	58.00		N/A	0.38	N/A	4.00	7.50	55.50	1.00	
	284/286	18.00	64.00		3.63	0.63	2.00	4.00	7.50	61.50	1.00	
	324/326	18.00	64.00		3.63	0.38	1.88	4.00	7.50	61.50	1.00	
	364/365	18.00	68.00		3.63	0.34	1.88	4.00	7.50	65.50	1.00	
M	284/286	24.00	68.00	19.25	5.25	1.28	N/A	4.75	9.50	65.50	1.00	6.50
	324/326	24.00	80.00	19.25	5.25	0.88	N/A	4.75	9.50	77.50	1.00	6.50
	364/365	24.00	80.00	19.25	5.25	0.25	N/A	4.75	9.50	77.50	1.00	6.50
	404/405	26.00	80.00	19.25	5.25	1.28	N/A	4.75	9.50	77.50	1.00	6.50
	444/445	26.00	98.00	19.25	7.25	0.25	N/A	4.75	9.50	95.50	1.00	6.50
	447/449	26.00	98.00	19.25	7.25	0.25	N/A	4.75	9.50	95.50	1.00	6.50

* For pump dimension D = 8.25, HD = 12.25, IF D = 10.00, HD = 14.00. ** Nominal dimension, excludes shims which may be up to 0.13 thick.

9.0 Recommended Spare Parts List

9.1 Recommended Spare Parts - Frame S - Horizontal

Service: _____ Pump No: _____
 Pump Size: _____ Serial No: _____

Number	Item	Size	Material
2	Impeller (includes O-Ring)	_____ Dia.	
38	O-Ring	2-024	PTFE
	Rotating Element: Complete Assembly	5308 / 6308	316SS/Steel
	By Components:		
6	Shaft Assembly		316SS/Steel
16	Radial Bearing	6308 C3	
18	Thrust Bearing	5308 AHC3	
35	Retainer Cover		Steel
	Thrust Bearing Labyrinth Seal		
89B	Rotor (includes O-Ring)	1.125	316SS
89C	O-Ring	2-024	FKM*
	Radial Bearing Labyrinth Seal		
89E	Rotor (includes O-Ring)	1.50	316SS
89F	O-Ring	2-029	FKM*
405	Thrust Cartridge O-Ring	2-155	Buna-N
73	Casing Gasket, 6 in.	.06 in.	Fiber filled Buna
73	Casing Gasket, 8 in.	.06 in.	Fiber filled Buna
80	Mechanical Seal Spare Parts Kit	1.500 in.	
	Shaft Wrench – Impeller Removal Tool		CI

*FKM – fluoroelastomer.

Open Impellers – CD4MCu

Size: 1 x 1.5 – 6, 2 x 3 – 6
 1 x 1.5 – 8, 1.5 x 3 – 8

Consult your distributor or the factory for Blackmer item numbers for the above component parts

9.2 Recommended Spare Parts - ANSI Frame A and Vortex - Horizontal

Service: _____ Pump No: _____
 Pump Size: _____ Serial No: _____

Number	Item	Size	Material
2	Impeller (includes O-Ring)	_____ Dia.	
38	O-Ring	2-027	PTFE
	Rotating Element: Complete Assembly		316SS/Steel
	By Components:		
6	Shaft Assembly		316SS/Steel
16	Radial Bearing	6310 C3	
18	Thrust Bearing (2 required)	7310 BEGAY	
35	Retainer Cover		Steel
62	Flinger		Nylon
	Thrust Bearing Labyrinth Seal		
89B	Rotor (includes O-Rings)	1.50	316SS
89C	O-Rings (2 required)	2-128	FKM*
	Radial Bearing Labyrinth Seal		
89D	Stator	1.88	NPS
89E	Rotor (includes O-Rings)	1.88	316SS
89F	O-Rings (2 required)	2-134	FKM*
405	Thrust Cartridge O-Ring	2-155	Buna-N
72	Frame Adapter O-Ring	2-265	Buna-N
73A	Casing Gasket, 8 in. and 10 in.	.06 in.	Fiber filled Buna
73A	Casing Gasket, 13 in.	.06 in.	Fiber filled Buna
80	Mechanical Seal Spare Parts Kit	1.875 in.	
	Shaft Wrench – Impeller Removal Tool		CI

*FKM – fluoroelastomer.

Open Impellers – CD4MCu

Size: 2 x 3 – 8, 3 x 4 – 8,
 1 x 2 – 10, 1.5 x 3 – 10, 2 x 3 – 10, 3 x 4 – 10, 4 x 6 – 10, 4 x 6 – 10PS
 1.5 x 3 – 13, 2 x 3 – 13, 3 x 4 – 13, 4 x 6 – 13, 4 x 6 – 13PS

Vortex Impellers – Ductile Iron

Size: 2 x 2 – 8
 3 x 3 – 10
 4 x 4 – 12

Consult your distributor or the factory for Blackmer item numbers for the above component parts

9.3 Recommended Spare Parts - LD17 and Vortex - Horizontal

Service: _____ Pump No: _____
 Pump Size: _____ Serial No: _____

Number	Item	Size	Material
2	Impeller (includes O-Ring)	_____ Dia.	
38	O-Ring	2-027	PTFE
	Rotating Element: Complete Assembly		316SS/Steel
	By Components:		
6	Shaft Assembly		316SS/Steel
16	Radial Bearing	6310 C3	
18	Thrust Bearing (2 required)	7310 BEGAY	
35	Retainer Cover		Steel
62	Flinger		Nylon
	Thrust Bearing Labyrinth Seal		
89B	Rotor (includes O-Rings)	1.50	316SS
89C	O-Rings (2 required)	2-128	FKM*
	Radial Bearing Labyrinth Seal		
89D	Stator	1.88	NPS
89E	Rotor (includes O-Rings)	1.88	316SS
89F	O-Rings (2 required)	2-134	FKM*
405	Thrust Cartridge O-Ring	2-248	Buna-N
72	Frame Adapter O-Ring	2-265	Buna-N
73A	Casing Gasket, 8 in. and 10 in.	.06 in.	Fiber filled Buna
73A	Casing Gasket, 13 in.	.06 in.	Fiber filled Buna
80	Mechanical Seal Spare Parts Kit	1.875 in.	
	Shaft Wrench – Impeller Removal Tool		CI

*FKM – flouorcarbon elastomer.

Open Impellers – CD4MCu

Size: 2 x 3 – 8, 3 x 4 – 8,
 1 x 2 – 10, 1.5 x 3 – 10, 2 x 3 – 10, 3 x 4 – 10, 4 x 6 – 10, 4 x 6 – 10PS
 1.5 x 3 – 13, 2 x 3 – 13, 3 x 4 – 13, 4 x 6 – 13, 4 x 6 – 13PS

Vortex Impellers – Ductile Iron

Size: 2 x 2 – 8
 3 x 3 – 10
 4 x 4 – 12

Consult your distributor or the factory for Blackmer item numbers for the above component parts

9.4 Recommended Spare Parts - Frame M - Horizontal

Service: _____ Pump No: _____
 Pump Size: _____ Serial No: _____

Number	Item	Size	Material
2	Impeller (includes O-Ring)	_____ Dia.	
38	O-Ring	2-034	PTFE
	Rotating Element: Complete Assembly		316SS/Steel
	By Components:		
6	Shaft Assembly (bi-metal)		316SS/Steel
16	Radial Bearing	6314	
18	Thrust Bearing (2 required)	7314 BEGAY	
35	Retainer Cover		Steel
62	Flinger		Aluminum
	Thrust Bearing Labyrinth Seal		
89B	Rotor (includes O-Rings)		316SS
89C	O-Rings (2 required)	2-146	FKM*
	Radial Bearing Labyrinth Seal		
89D	Stator		NPS
89D	Stator O-Rings	2-161	FKM*
89E	Rotor (includes O-Rings)		316SS
89F	Rotor O-Rings (2 required)	2-146	FKM*
405	Thrust Cartridge O-Ring	2-262	Buna-N
73A	Casing Gasket, 13 in.	.06/.09 in.	Fiber filled Buna
73A	Casing Gasket, 15 in.	.06/.09 in.	Fiber filled Buna
80	Mechanical Seal Spare Parts Kit	2.625 in.	
	Shaft Wrench – Impeller Removal Tool		CI

*FKM – fluoroelastomer.

Open Impellers – Ductile Iron

Size: 6 x 8 – 13, 8 x 10 – 13
 6 x 8 – 15, 8 x 10 – 15

CD4MCu

Size: 6 x 8 – 13, 8 x 10 – 13
 6 x 8 – 15, 8 x 10 – 15

CF8M (316SS)

Size: 4 x 6 – 17, 6 x 8 – 17, 8 x 10 – 17

Consult your distributor or the factory for Blackmer item numbers for the above component parts

10.0 Pump Tolerances

Shaft Diameters	Frame S inches (mm)	Frame A/LD17, VORTEX inches (mm)	Frame M inches (mm)
Bearing journals (both)	1.5753 / 1.5749 (40.013 / 40.002)	1.9690 / 1.9686 (50.013 / 50.002)	2.7565 / 2.7560 (70.015 / 70.002)
Under mechanical seal	1.501 / 1.499 (38.125 / 38.075)	1.876 / 1.874 (47.650 / 47.600)	2.624 / 2.623 (66.650 / 66.624)
Under thrust lab seal	1.127 / 1.123 (28.626 / 28.524)	1.502 / 1.498 (38.151 / 38.049)	2.625 / 2.623 (66.675 / 66.624)
Coupling End	.874 / .873 (22.200 / 22.174)	1.3750 / 1.3745 (34.092 / 34.912)	2.3745 / 2.3735 (60.312 / 60.287)
Impeller thread	.750-10UNC-2A	1.000-12UNF-2A	1.500-8UN/1.750-12UNJ
Impeller tightening torque	Snug-metal to metal	Snug-metal to metal	Snug-metal to metal
Allowable runout	.001T.I.R. (0.025)	.001T.I.R. (0.025)	.001T.I.R. (0.025)

Bearing Housing

Radial bearing bore	3.5444 / 3.5434 (90.028 / 90.002)	4.3321 / 4.3307 (110.035 / 110)	5.9071 / 5.9055 (150.04 / 150)
Thrust bearing cartridge bore	4.1885 / 4.1875 (106.388 / 106.363)	5.126 / 5.125 (130.200 / 130.175)	7.251 / 7.250 (184.175 / 184.150)

Cartridge

Bore	3.5444 / 3.5434 (90.028 / 90.002)	4.3321 / 4.3307 (110.035 / 110)	5.9060 / 5.9044 (150.012 / 149.972)
Outside diameter	4.1870 / 4.1860 (106.350 / 106.324)	5.1245 / 5.1235 (130.162 / 130.137)	7.2494 / 7.2487 (184.135 / 184.117)

11.0 Fastener Torque Values

Bolt Size	Item	Steel Grade 5 in-lbf (N-m)	Stainless Steel in-lbf (N-m)
8 - 32	Frame S Retainer Cover	13 (1.5)	N/A
10 - 32	Frame A Retainer Cover	49 (5.5)	N/A
12 - 24	Motor Shroud	72 (8.1)	N/A
.25 - 20	Back Cover/Bearing Frame	96 (10.8)	66 (7.4)
		ft-lbf (N-m)	ft-lbf (N-m)
.31 - 18	Back Cover/Bearing Frame	17 (23)	11 (15)
.31 - 24	Frame M Retainer Cover	18 (24)	
.37 - 16	Back Cover/Frame Adapter	30 (41)	20-25 (27-34)
.37 - 16	Seal Gland Nuts		15-20 (20-27)
.37 - 24	Frame S Micrometer Nuts		20 (27)
.50 - 13	Power End/Casing Feet	75 (102)	40-50 (54-68)
.50 - 13	Casing/Adapter Plate		40-50 (54-68)
.50 - 13	Seal Gland Nuts		20-30 (27-41)
.50 - 20	Frame A Micrometer Nuts		30-40 (41-54)
.50 - 20	Key Driven Impeller Bolt		100 (136)
.62 - 11	Casings	150 (203)	100 (136)
.62 - 11	Power End	125 (169)	100 (136)
.62 - 11	Seal Gland Nuts		25-35 (34-47)
.75 - 10	Casing Feet	260 (352)	175 (237)
.88 - 9	Casing/Frame Adapter		108 (146)
.12 - 27 NPT	Frame S Back Covers		15 (20)
.25 - 18 NPT	Back Covers		16-19 (22-26)
.38 - 18 NPT			32-35 (43-47)
.50 - 14 NPT	Magnetic Plugs	45-55 (61-75)	
.75 - 14 NPT	Drain Plug	30 (41)	
.75 - 14 NPT	Oil Sight Glass	30 (41)	
.75 - 14 NPT	Oil Filler Cap	15 (20)	
1.00 - 11.5 NPT	Oil Sight Glass	40-60 (54-81)	
.750 - 10UNC - 2A	Frame S Impeller		Hand tighten until snug
1.00 - 12UNF - 2A	Frame A Impeller		
1.50 - 8UN	Frame M Impeller		
1.75 - 12UNJ	Frame M 17 in. Impeller		

Torque values shown are for standard pump materials and components.
For specials, factory must be consulted.

12.0 Ball Bearings

12.1 Ball Bearing Handling, Removal And Inspection

Ball bearings are carefully designed and made to precision tolerances. They give long, trouble-free service when properly applied and maintained. They will not stand abuse.

Keep Clean

Dirt causes 90% of early bearing failures. Cleanliness is a must when working on bearings.

The following procedures are important:

- Spread clean newspapers on work benches and at pump. Set tools and bearings on newspapers only.
- Wash hands.
- Wipe dirt, chips, and grease off tools.
- Keep bearings, housings, and shaft covered with clean cloths whenever they are not being worked on.
- Do not unwrap new bearings until ready to install.
- Flush shaft and housing with clean solvent before re-assembly.

Remove Bearings Carefully

- Use bushing or puller which contacts the inner race of the bearing.
- Never press against the balls or ball cages, only against the races.
- Do not cock bearing.
Use sleeve which is machined square, or puller which is adjusted square.

Inspect Bearings And Shaft

- Inspect bearing carefully.
Replace it if there are any flat spots, nicks or pits on the balls or races. Bearings should be in perfect shape.
- Turn bearing over slowly by hand. It should turn smoothly and quietly. Replace if it catches or is noisy. Please note that when turning over a shaft in a rotating element, the bearing cage can make a rattle sound, this is normal.
- Check condition of shaft. Bearing seats should be smooth and free from burrs. Smooth any burrs with crocus cloth.

Install New Bearings Carefully

1. Check the new bearing to be sure it has the proper bearing number, prefix and/or suffix.
2. Lightly oil the bearing seat on the shaft.
3. Angular contact bearings must be installed back-to-back i.e. with letters-to-letters.
See section 12.2 “Angular Contact Bearing Assembly Procedure”.
4. Press bearing onto shaft squarely. Do not cock it on the shaft.
Be sure that the sleeve or bushing used to press on the bearing inner race is clean, and machined square on the ends.
5. Press the bearing firmly up against the shaft shoulder. The shoulder helps support and square the bearing.
6. Be sure the locknut is on tight.
7. Lubricate properly, as explained in section 2.8.

12.2 Angular Contact Bearing Assembly Procedure

A bearing induction heater with a demagnetizing cycle is the best tool for mounting bearings on a shaft. Other heating techniques or pressing increase the risk of bearing contamination and/or damage.

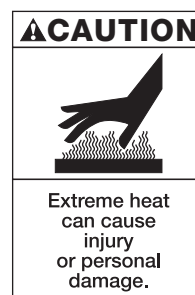

WARNING:
Wear insulated gloves when using a bearing heater. Hot bearings can cause physical injury.

1. Inspect the shaft to ensure it is clean, dimensionally correct and without burrs or nicks. Lightly coat the bearing seating area with a film of light oil. If the radial bearing is already installed, be sure to slide the retainer cover over the shaft with the small lip (if present) facing the thrust bearing end.

2. After removing the bearing from the packaging, clean the preservative from the bearing bore and outer race.
 3. Place both angular contact bearings on the bearing induction heater. Heat to 240°F (116° C), checking the temperature of the bearing with an appropriate means. Use the demagnetizing cycle.
 4. Remove one bearing from the heater with insulated gloves.
 5. Place the first bearing on the thrust bearing journal of the shaft. The large shoulder of the inner race of the bearing should be seated against the shaft shoulder.
- NOTICE:**
Angular Contact Bearings are mounted “back-to-back”, i.e. the letter designations on the bearing races must be facing each other.
6. Quickly, place the second bearing on the shaft tight against the first bearing. The large shoulder of the inner race of the bearing should be facing the threads on the shaft.
 7. Place a sleeve over the shaft against the inner race of the bearing. Tap the sleeve lightly and evenly to insure the bearings are tight against each other.
 8. Install the lockwasher on the shaft so that the tab is in the keyway.
 9. Screw on the locknut and tighten with a spanner wrench per the allowable torque values shown on the chart below. The tab of the lockwasher should be bent over into one of the grooves in the locknut.
 10. After the bearings have cooled, check that the bearings are tight to the shaft shoulder and the outer races do not move relative to each other. If there is any clearance noted or the bearing races move independently, the bearing must be reset. Remove the locknut and use an arbor press with a sleeve to press on the inner bearing race, eliminating any clearance.
 11. Lightly oil the OD of the bearing and slide the bearing cartridge over the bearing.
 12. Fasten the retainer cover with the socket head cap screws by tightening each screw in an alternating pattern. Torque each screw to the value as shown on the chart below.

12.3 Double Row Bearing Assembly Procedure

The Frame S pump uses a double row, 5308 thrust bearing, otherwise the procedure is the same as in steps 1 through 12 above. Locknut tightening torques are listed in the table below.

Maximum Allowable Tightening Torque For Bearing Locknuts

Bearing Designation Maximum Allowable	Locknut Designation	Maximum Allowable Clamping Force (lbf)	Tightening Torque (ft-lbf)
5308	N-08	1602.5 (7.1 kN)	35 (47 N-m)
7310 BEA	N-10	2475.0 (11.0 kN)	70 (95 N-m)
7314 BEA	N-14	4400.0 (19.6 kN)	170 (231 N-m)

Retainer Cover Screws Tightening Torque

Frame S	8 - 32	13 in-lbs (1.5 N-m)
Frame A	10 - 32	49 in-lbs (5.5 N-m)
Frame M	0.31 - 24	18 ft-lbs (24.4 N-m)

13.0 Pump Component Inspection

Casing

⚠CAUTION

Heavy assemblies can cause personal injury or property damage.

WARNING:
Pump and components are heavy. Failure to properly lift and support equipment could result in physical injury or damage to pump. Steel toed shoes should be worn at all times.

1. Inspect inner face where impeller runs for any deep gouges made from impeller rubbing or material caught in the impeller. Gouges up to .125 in. (3 mm) deep are acceptable for pump operation as long as pump system pressure is below 150 psig (10 bar).
2. If there are numerous gouges and scratches, original performance characteristics may be affected. If damage is severe the casing may not be able to handle the system pressure and should be replaced.
3. The vortex pump has a separate suction cover that can be replaced if necessary.

Impeller

⚠WARNING

Hazardous machinery can cause serious personal injury.

WARNING:
Wear heavy gloves when handling impeller as sharp edges may cause physical injury.

1. Inspect face of impeller for gouges on blades. Clean up any burrs with a file or grinding wheel. If the impeller has severely rubbed against the casing face, it should be replaced as the efficiency and flow will not be maintained to original specifications.
2. If impeller is cut to a new diameter, it should be rebalanced to ISO G6.3 balance specification.
3. If impeller was difficult to remove, impeller thread should be rechased with a tap. See section 11.0 for thread sizes.
4. If the impeller shows excessive erosion, corrosion, extreme wear or vane breakage, it should be replaced.

Back Cover

1. Inspect gasket face of stuffing box where mechanical seal gasket seats. If the face is gouged or nicked, a cut can be taken on a lathe duplicating the existing gasket surface finish. Maximum stock removal .040 in. (1.0 mm).
2. Inspect back face for gouges or nicks and inner surface of seal chamber for serious erosion, i.e. wall thickness worn to less than .350 in. (9 mm) for Frame S or .420 in. (11 mm) for Frames A, LD17 and M. Unless seriously damaged, remove any burrs and reuse cover.

Frame Adapter

- Inspect faces to insure there are no cracks in flange rings or extending from bolt holes. Inspect labyrinth seal stator for signs of rubbing. If damaged seriously, i.e. rub more than 1/3 of circumference, replace.

Bearing Frame

- Inspect bearing bore dimensions per pump tolerance chart, section 10.0.
- Check sump for dirt or contaminants and clean as necessary.

Cartridge

- Inspect bore and O.D. of cartridge dimensions per pump tolerance chart, section 10.0.
- Inspect labyrinth seal stator for signs of rubbing. If damaged seriously, i.e. rub more than 1/3 of circumference, then replace cartridge.

Shaft

- Inspect shaft journal diameter dimensions per pump tolerance chart, section 10.0.
- Inspect shaft runout at mechanical seal area, impeller end, and at coupling end with a dial indicator. Use "V" blocks under the journals to fixture shaft while rotating and reading dial indicator. Acceptable runout allowances can be found on chart in section 10.0.
- Inspect shaft for any scratches or nicks. If found under journals or anywhere along the shaft where labyrinth seal o-rings will slide, file or stone smooth. If found under the mechanical seal, check location of o-ring on seal sleeve where it sits on shaft (measure location of o-ring in seal sleeve) to be sure it won't seat over the damaged area. If the seal o-ring sits on a damaged area, the shaft should be replaced.
- Inspect shaft thread. If there was difficulty removing the impeller, the thread should be chased with the appropriate die or cleaned with a thread file. See section 11.0 for thread sizes.

Bearings

When a pump is removed for mechanical seal or impeller replacement, it is not necessary to replace the bearings unless they are nearing the end of their operating life or inspection reveals the following:

- Flat spots on balls
- Discoloration
- Runs rough when spun
- Bearing catches in one spot when spun

NOTE:

A bearing will sound somewhat noisy due to the metal cage around the balls, if in doubt, replace the bearing. However, be aware that needless replacement of bearings is more potentially problematic than leaving them on the shaft since removal can cause shaft damage and improper placement can result in premature failure.

- Be sure to replace bearings with an identical model and size. Note that suffix letters are important. See bearing listing under respective pump size in section 9.0.

Lab Seal Rotors

- Replace the labyrinth seal rotor if there is a rub mark more than 1/3 around circumference at any diameter or if seizing has occurred and shaft has spun inside, thus wearing the o-ring grooves.

C-Frame Adapter and Feet

- Check for any cracks in the casting mounting rings or foot slots, replace as necessary.

Hardware, Gaskets, O-rings

- Check all hardware for clean threads. Hardware with threads that are broken or distorted should be replaced.
- Clean all gasket surfaces to remove any residual gasket material.
- Replace all gaskets and o-rings.

14.0 Troubleshooting

Pump Does Not Deliver Liquid

- Pump not primed
- Pump suction pipe not completely filled with liquid
- Insufficient available NPSH
- Air pocket in suction line
- Inlet of suction pipe insufficiently submerged
- Pump operated with closed or partially closed suction valve
- Clogged suction strainer
- Obstruction in suction line
- Clogged impeller
- Speed of pump too low
- Wrong direction of rotation
- Impeller diameter smaller than specified
- Static head higher than shut-off head
- Total head of system higher than design of pump
- Parallel operation of pumps unsuitable for this purpose
- Viscosity of liquid differs from design conditions

Insufficient Capacity Delivered

- Pump suction pipe not completely filled with liquid
- Insufficient available NPSH
- Excessive amount of air or gas in liquid
- Air pocket in suction line
- Air leaks into suction line
- Air leaks into pump through mechanical seal
- Inlet of suction pipe insufficiently submerged
- Vortex formation at suction
- Pump operated with closed or partially closed suction valve
- Clogged suction strainer
- Obstruction in suction line
- Excessive friction losses in suction line
- Clogged impeller
- Two elbows in suction piping at 90° to each other, creating swirl and prerotation
- Speed of pump too low
- Wrong direction of rotation
- Uncalibrated instruments
- Impeller diameter smaller than specified
- Friction losses in discharge higher than calculated
- Total head of system higher than design of pump
- Viscosity of liquid differs from design conditions
- Foreign matter in impellers

Insufficient Pressure Developed

- Excessive amount of air or gas in liquid
- Air leaks into suction line
- Air leaks into pump through mechanical seal
- Inlet of suction pipe insufficiently submerged
- Vortex formation at suction
- Pump operated with closed or partially closed suction valve
- Clogged suction strainer
- Obstruction in suction line
- Excessive friction losses in suction line
- Clogged impeller
- Two elbows in suction piping at 90° to each other, creating swirl and prerotation
- Speed of pump too low
- Wrong direction of rotation
- Uncalibrated instruments
- Impeller diameter smaller than specified
- Specific gravity of liquid differs from design conditions
- Viscosity of liquid differs from design conditions
- Foreign matter in impellers

Pump Losses Prime After Starting

- Pump suction pipe not completely filled with liquid
- Excessive amount of air or gas in liquid
- Air leaks into suction line
- Air leaks into pump through mechanical seal
- Source of sealing liquid has air in it
- Inlet of suction pipe insufficiently submerged
- Vortex formation at suction

Excessive Power Consumption

- Pump speed too high
- Impeller diameter larger than specified
- Binding rotating element
- Impeller rubbing the casing or backcover
- Bent shaft
- The mechanical seal binding
- Specific gravity higher than anticipated
- Viscosity higher than anticipated
- Solids concentration higher than anticipated (Vortex only)
- The pump and driver shafts misaligned
- Wrong direction of rotation
- Uncalibrated instruments
- Total head of system higher than design of pump
- Total head of system lower than design of pump
- Running pump at too high a flow
- Foreign matter in propeller
- Misalignment

Cavitation

- Insufficient suction head available (NPSHA)
- Operating at a higher capacity than specified
- Excessive air or gas entrainment
- Vortexing in the pump suction or intake system
- Liquid temperature higher than the vapor temperature
- Air leak in the pump or suction line
- Partially plugged suction
- Elbow too close to the pump suction
- Temperature too low, thereby increasing liquid viscosity

Vibration

NOTE:

The major frequency of the vibration can help to pinpoint the source

- Pump cavitation
- Worn ball bearings
- Impeller rubbing the casing bowl or backcover
- Shaft binding
- Bent shaft
- Impeller out of dynamic balance
- Pump and driver shafts severely out of alignment
- Insufficient bearing lubrication
- Worn motor bearings
- Pump improperly assembled
- A worn or defective discharge valve that may be fluttering
- Pump suction pipe not completely filled with liquid
- Clogged impeller
- Transients at suction source (imbalance between pressure at surface of liquid and vapor pressure at suction flange)
- Foundations insufficiently rigid
- Loose foundation bolts
- Loose pump or motor bolts
- Inadequate grouting of baseplate
- Excessive forces and moments from piping on pump nozzles
- Improperly mounted expansion joints
- Resonance between operating speed and natural frequency of foundation of baseplate or of piping
- Lack of lubrication of certain couplings
- Excessive grease or oil in anti-friction bearing housings
- Moisture contamination of lubricant

Pump Vibrates or is Noisy at High Flows

- Pump suction pipe not completely filled with liquid
- Insufficient available NPSH
- Vortex formation at suction
- Pump operated with closed or partially closed suction valve
- Clogged suction strainer
- Obstruction in suction line
- Excessive friction losses in suction line
- Clogged impeller
- Two elbows in suction piping at 90° to each other, creating swirl and prerotation
- Total head of system lower than design of pump
- Running pump at too high a flow (for low specific speed pumps)
- Excessive wear at internal running clearances

Pump Vibrates or is Noisy at Low Flows

- Pump suction pipe not completely filled with liquid
- Insufficient available NPSH
- Selection of pump with too high a suction specific speed
- Running the pump against a closed discharge valve without opening a by-pass
- Operating pump below recommended minimum flow
- Running pump at too low a flow (for high specific speed pumps)
- Parallel operation of pumps unsuitable for this purpose
- Excessive radial thrust in single-volute pumps

Premature Bearing Failure

- See Items under “Vibration”
- Frequency of lubrication is too low (grease), or the quantity of lubrication is insufficient
- Wrong type of oil or grease for the pump load, speed and temperature involved
- Inadequate water or air cooling to the bearing housing, cooling jacket, or heat exchanger
- Lubricant has undergone viscosity breakdown
- Lubricant contamination
- Bearing replacements that do not conform to the pump manufacturer’s specifications. See section 9.0
- Bearings improperly installed
- Pump cavitation. See items under “Cavitation”
- Belts on the belt drive too tight, causing excessive loading (Belt drive units only)
- Shaft diameter under the bearing inner race does not conform to the manufacturer’s specifications. See section 10.0.
- Bearing mounting diameter not conforming to the pump manufacturer’s specifications. See section 10.0.
- Excessive pipe stress
- Shaft misalignment with the driver causing excessive loading

Checks that can be made while the Pump is Inoperative

Partial or complete disassembly may be required

- Impeller Clearance
- Coupling Alignment
- Impeller Size
- System Obstructions (Check Valve)
- Pipe Stress
- Bearing Fits
- Mechanical Seal Condition
- Shaft Run-Out
- Wet End Inspection
- Condition of Lubricant
- Oil Level

Checks that can be made while the Pump is in Operation

- Rotation
- Foundation Condition
- Suction Pressure
- Discharge Pressure
- Speed
- Oil Temperature
- Amperage Draw
- Flow
- Vibration
- Listen for Unusual Noises
- Loose Fasteners
- Drive Noise

Notes

Notes

Notes

Notes

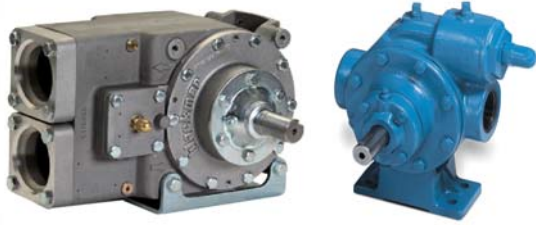

Sliding Vane Pumps: 5 to 2200 GPM
Refined Fuels, Liquefied Gases, Process,
Transport, Marine

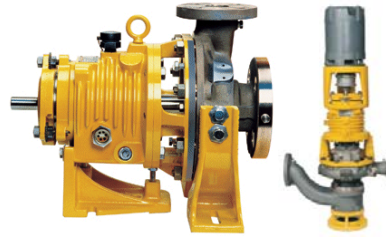

System One Centrifugal Pumps
10 to 7500 GPM
Process, Marine



C-Series Eccentric Disc Pumps
1 to 150 GPM
Shear Sensitive, Food, Process



Abaque Peristaltic Hose Pumps
0.5 to 220 GPM
High Lift, Solids, Abrasives



Rotary Vane and Screw Compressors
Dry Bulk Unloading



Reciprocating Gas Compressors
Liquefied Gas Transfer, Boosting, Vapor Recovery



Hydraulic Coolers
Complete Packages



Magnetic Drive Pumps
Iron and Stainless, 14 to 333 GPM



Hand Operated Pumps
Dispensing, Transfer, In-line



Accessories
Gear Reducers, Bypass Valves, Strainers

Visit www.blackmer.com for complete information on all Blackmer products



1809 Century Avenue, Grand Rapids, Michigan 49503-1530 U.S.A.
Telephone: (616) 241-1611 • Fax: (616) 241-3752
E-mail: blackmer@blackmer.com • Internet Address: www.blackmer.com